

Quest H5

Installation, Operation and Maintenance Instructions

– Read and Save These Instructions –

This manual is provided to acquaint you with the Quest H5 air mover so that installation, operation and maintenance can proceed successfully. Ultimate satisfaction depends on the quality of set up and a thorough understanding of this equipment. The Quest H5 is built around tested engineering principles and has passed a thorough inspection for quality of workmanship and function.

Quest H5:

- Compact design
- Variable speed flow
- Multiple ducting options
- Tough, plastic cabinet
- Optional carbon filter



Patent Pending



 **Therma-Stor[®] LLC**
Driven by performance. Powered by design.™

4201 Lien Rd
Madison, WI 53704
www.QuestClimate.com

Phone 608-237-8400
Toll-Free 1-877-420-1330
info@QuestClimate.com

Table of Contents

- Introduction 1
- 1. Specifications..... 2
- 2. Important Safety Instructions..... 2
- 3. Operation..... 2
 - 3.1 Transporting the Quest H5 2
 - 3.2 Electrical Requirements..... 2
 - 3.3 Air Ducting..... 3
 - 3.3A Inlet Ducting..... 3
 - 3.3B Outlet Ducting..... 3
 - 3.3C Negative Air Ducting 3
 - 3.4 Power/Speed Control..... 3
 - 3.5 Resettable Circuit Breaker 4
 - 3.6 GFCI Protection and On-Board Duplex VAC Outlet..... 4
 - 3.7 Servicing..... 4
- 4. Maintenance 4
 - 4.1 Air Filters..... 4
 - 4.2 Filter Replacement..... 4
 - 4.2A Filter change light 4
 - 4.2B Optional Activated Carbon/Potassium Permanganate filters..... 5
- 5. Service 5
 - 5.1 Warranty..... 5
- 6. Wiring Diagram 6
- 7. Service Parts 7
 - Warranty 9

Serial No. _____

Purchase Date ____/____/____

Dealer's Name _____



1. Specifications

Part No.	4031450
Power	110-120 Vac, 2.4 amps
Blower	500 CFM
Filters:	1st stage 1" Pleated Media, 18" x 18" (optional) 1" Carbon and Potassium Permanganate 2nd stage 2.5" Pleated HEPA 18" x 18"
Warranty	One Year, 100% Parts and Labor
Dimensions	Width 22" Height 14" Depth 24" Weight 33 lbs.

2. Important Safety Instructions

CAUTION: Risk of electric shock. Can cause injury or death to reduce the risk of electric shock:

- Do not expose to standing water or rain
- Connect to GFCI outlet
- Do not use an extension cord
- Unplug fan before servicing or changing filters.
- Do not block air intake or outlet. One foot minimum distance to obstructions.
- Indoor use only
- Do not use as stool or bench
- Do not operate with damaged cord or plug.
- Do not run cord under carpeting. Do not cover cord with throw rugs, runners, or similar coverings. Do not route cord under furniture or appliances. Arrange cord away from traffic area and where it will not be tripped over."

3. Operation

3.1 Transporting the Quest H5

The H5 should be transported vertically or horizontally on the appropriate feet located on the bottom of the unit or opposite the handle.

3.2 Electrical Requirements

The Quest H5 HEPA System can be plugged into a grounded 15 Amp circuit. It draws about 2.4 Amps with clean filters and no ducting. The amp draw will decrease slightly with added ducting and as the filters load with particulate. Due to the presence of GFCI receptacle, the unit must be plugged directly into a wall outlet. No extension cords should be used.

3.3 Air Ducting

3.3A Inlet Ducting

Occasionally the area to be filtered is difficult to access and/or the unit cannot be located in the area. In such cases, the air can be ducted to the unit's inlet.

A round 16" diameter flexible duct can be attached to the unit inlet. It connects by placing the wire in the duct over the duct collar lip at one location and working over it over the lip gradually. It may be removed after use for easier transport and storage. Flexible 16" duct is available from Therma-Stor LLC. (4028357)

3.3B Outlet Ducting

A detachable trapezoid shaped exhaust ring is supplied that will allow 10" round lay-flat plastic duct to be attached to the Quest H5 HEPA System outlet. Lay-flat plastic ducting is available from Therma-Stor LLC. (4024935)

To attach ducting to the collar, remove the ring from the unit by pressing release tab at the top of the grill. Put the plastic duct end through the inside of the ring. Roll the duct end outward so that it over-laps the outside of the ring. Clip the ring back onto the exhaust grill.

3.3C Negative Air Ducting

The Quest H5 HEPA System can be used to filter and exhaust air from a space. When exhausting to outside the space, the space will be under a slight negative pressure. This will help prevent airborne particles from leaving the space, because the negative pressure will draw air in through openings in the space's exterior surfaces.

CAUTION: Exhausting too much air from a space with open combustion devices (e.g. furnace, fireplace or water heater) can cause those devices to backdraft. This can contaminate the space with potentially fatal gases.

In such cases, the Quest H5 HEPA System must be used in one of the following three ways:

- A. As a filtering unit only. Exhausting no air from the space and thus causing no negative pressure or backdrafting.
- B. Exhausting a very limited amount of air which does not cause backdrafting. In case B, the open combustion devices must be thoroughly checked to guarantee that they do not backdraft while the Quest H5 HEPA System is running.
- C. Direct the outlet duct from the H5 HEPA System to the room with the open combustion device(s). This will positively pressurize the room with HEPA filtered air, thus preventing backdrafting. As in case B, those combustion devices must be checked after the H5 HEPA System is running to guarantee that they are not backdrafting.

3.4 Power/Speed Control

The power/speed switch is located on the control panel. When turned on to any speed, it powers the impeller fan.

Occasionally the impeller fan may not start on low speed. If this occurs, rotate the speed control to high speed until the impeller fan starts, then adjust it to a lower speed.

CAUTION: Do not remove HEPA filter with the unit on. Removing the top and filters while running will expose the dangerous rotating impeller fan. Disconnect the appliance before changing filters.

3.5 Resettable Circuit Breaker

The 12 AMP thermal response resettable circuit breaker protects the unit and devices connected to its duplex GFCI outlet.

The circuit breaker is designed to sense the total current draw through the circuit. The circuit breaker "trips" when more than 12 amps of electrical current are drawn through the device's power cord. Should an over-current condition occur, the H5 on-board circuit breaker prevents nuisance visits to a remote power junction box.

IMPORTANT: Total amperage of the H5 plus all devices plugged into the receptacle must not exceed 12 amps. The circuit breaker will not allow for loads in excess of 12 amps, although there is a time delay before the overloaded circuit is broken.

IMPORTANT: When the Quest H5 is plugged into a standard “powered” wall outlet the Quest H5’s duplex outlet is electrically “HOT” and AC voltage is present

3.6 GFCI Protection and the On-Board Duplex VAC Outlet

The standard AC voltage outlet GFCI (Ground Fault Circuit Interrupter) protection promotes operator safety in wet applications. GFCI devices trip when a fault to electrical “ground” is sensed.

It is recommended to check the GFCI protection prior to operation. To check, push the “TEST” button located on the GFCI duplex outlet. If operating properly the “RESET” button on the GFCI outlet will pop out. A tripped GFCI is indicated by a small LED. The device can only be “RESET” when the H5 is connected to a wall outlet providing standard voltage. This duplex AC outlet allows the inter-connection of other AC powered devices. The sum total amperage of all devices plugged into the receptacle must not exceed 10 amps.

3.7 Servicing

Before each use inspect for damage, blocked inlet or outlet.

Inspect the GFCI to ensure it is not in a “tripped” condition. Push “RESET” to reset the GFCI.

When the Quest H5 is first turned on, check for excessive vibration. If the unit vibrates excessively or if impeller rubs on housing, turn off the unit immediately. Have a service technician inspect the unit to locate the problem.

4. Maintenance

Use extreme caution when changing the HEPA filter as hazardous material could be trapped in the media. Always make sure to dispose of filters in the appropriate way. If you are unsure of how to safely dispose of any filter-consult an industrial hygienist to ensure that all hazardous materials are contained and disposed of properly.

4.1 Air Filters

The standard Quest H5 HEPA System is equipped with two filters that progressively filter out smaller particles. An optional activated carbon/potassium permanganate filter can be also added. These filters must be checked regularly. Operating the unit with dirty filters will reduce the airflow, but will do no harm to the unit. The unit can be run indefinitely with dirty filters.

The two standard filters used are listed below (as installed in the unit from top to bottom):

- A. 25 to 30% efficient (per ASHRAE 52.1-1992), MERV-7, pleated fabric pre-filter.
- B. 99.97% DOP efficient HEPA filter.

4.2 Filter Replacement

4.2A Filter Change Light

When the green “filter change light” illuminates. It may be time to replace one or both filters.

To check airflow accurately, an airflow meter or anemometer must be used:

When the filter change light illuminates; remove all ducting and run on high speed. If the filter light remains lit; replace the pre-filter and run on high again. If the light remains; it is time to replace the HEPA filter for full 500 CFM performance.



Airflow on high speed with all filters clean and no ducting is slightly over 500 CFM. The unit can be run with very dirty filters and virtually no flow without harming the unit. The operator's decision to change filters should be based on filter cost vs. the unit's filtering effectiveness. If airflow is 250 CFM vs. 500 CFM, the unit will filter particles from a space at half the rate. The operator must judge if that is acceptable.

If the operator determines the filters should be changed due to low airflow, it is most economical to change them in the following order:

Change the pre-filter (top) first. This is the least expensive filter. Recheck the airflow. If the airflow is acceptable, no other filters need to be changed.

If the airflow is still too low, the HEPA filter must be changed. To remove the HEPA filter, follow these steps:

1. Loosen the eight screws one revolution
2. Rotate all eight clips out of the way.
3. Remove old filter.
4. Installing the new filter is the reverse of these instructions

4.2B Optional Activated Carbon/Potassium Permanganate Filters

Optional gas phase filters are available from Therma-Stor. They use a blend of activated carbon and potassium permanganate. This blend removes the vast majority of gaseous contaminants encountered in most filtering applications. The activated carbon removes the heavier volatile organics while the potassium permanganate removes lower molecular weight contaminants. This is well suited to the smoke odors present after fire damage.

The life of the media blend depends upon both the hours used and the contamination level. Another advantage of the blended media versus activated carbon only is that part of the blend changes color as it loads up with contaminants. It starts out black, then turns pink, then brown, and finally white. It is best changed when it passes the brown stage and begins to turn white. It has lost most of its effectiveness at that point.

The filter is the same size as the pleated fabric filter. Install it in place of the pleated fabric filter.

5. Service

CAUTION: Servicing the Quest H5 HEPA System with its high voltage circuitry presents a health hazard that could result in death, serious bodily injury, and/or property damage. Disconnect the appliance from the power supply before servicing. Only qualified service people should service this unit.

5.1 Warranty

A warranty certificate has been enclosed with this unit. Read it before any repair is initiated. If a warranty repair is required, call the factory first at 1-800-533-7533 for warranty claim authorization and technical assistance.

6. Wiring Diagram

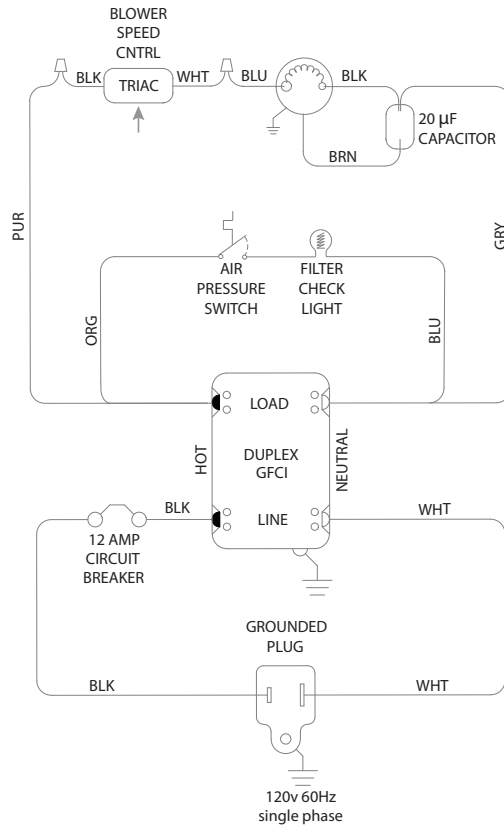

7. Service Parts

Item	Part No.	Description
1	4031877	Air Filter, Pleated, 1" x 18" x 18"
2	4031864	Air Filter, HEPA, 2.5" x 18" x 18" (99.97% Efficient)
3	4031863	HEPA filter hold down clip
4	4035832	Impeller Fan
5	4032854	Impeller Fan Speed Control
6	4032143	Impeller Fan Speed Control Knob
7	4037569	Cord (14ga, 25')
8	4033031-08	Run Capacitor, 20 mfd, 370 VAC
9	4031861	10" Lay flat duct collar ring

Optional Parts

Item	Part No.	Description
4031878		Air Filter, Disposable Carbon/Potassium Permanganate
4028357		Duct, Flex, 16" x 25'
4024935		Duct, Lay Flat, 10" x 250'

Quest H5 Limited Warranty

Warrantor:

Therma-Stor LLC
4201 Lien Rd
Madison, WI 53704
Telephone: 1-866-933-7486

Who Is Covered: This warranty covers Quest H5.

First Year Warranty: 100% parts and labor (all components)

End-User Responsibilities: Warranty service must be performed by a servicer authorized by Therma-Stor Products. To obtain warranty service you must obtain a return material authorization (RMA). To obtain an RMA you must present proof of purchase or (lease), by use of a warranty card, original sales receipt or other reasonable and reliable means.

To obtain an RMA call Therma-Stor LLC at the above number and ask for the Therma-Stor LLC Service Department, which will then issue an RMA# and arrange for, at our option, either repair or replacement.

Freight: Freight to and from the servicer is the responsibility of the end-user. The end-user is responsible for normal care and proper return packaging.

Limitations and Exclusions: This warranty does not cover any defect, malfunction, etc. resulting from misuse, abuse, lack of normal care, corrosion, freezing, tampering, modification, unauthorized or improper repair or installation, accident, acts of nature or any other cause beyond Therma-Stor LLC's reasonable control.

If any Quest H5 part is repaired or replaced, the new part shall be warranted for the balance of original warranty (but all warranty periods will be extended by the period of time, if any, that the Quest H5 with FOCUS Technology is out of service while awaiting covered warranty service).

Warranty service will be performed during normal working hours.

UPON THE EXPIRATION OF THE WRITTEN WARRANTY APPLICABLE TO THE QUEST H5 OR ANY PART THEREOF, ALL OTHER WARRANTIES IMPLIED BY LAW, INCLUDING MERCHANTABILITY AND FITNESS FOR A PARTICULAR PURPOSE, SHALL ALSO EXPIRE. ALL WARRANTIES MADE BY THERMA-STOR LLC ARE SET FORTH HEREIN, AND NO CLAIM MAY BE MADE AGAINST THERMA-STOR BASED ON ANY ORAL WARRANTY. IN NO EVENT SHALL THERMA-STOR LLC, IN CONNECTION WITH THE SALE, INSTALLATION, USE, REPAIR OR REPLACEMENT OF ANY QUEST H5 OR PART THEREOF BE LIABLE UNDER ANY LEGAL THEORY FOR ANY SPECIAL, INDIRECT OR CONSEQUENTIAL DAMAGES INCLUDING WITHOUT LIMITATION WATER DAMAGE (THE END USER SHOULD TAKE PRECAUTIONS AGAINST SAME), LOST PROFITS, DELAY, OR LOSS OF USE OR DAMAGE TO ANY REAL OR PERSONAL PROPERTY.

Some states do not allow limitations on how long an implied warranty lasts, and some do not allow the exclusion or limitation of incidental or consequential damages, so one or both of these limitations may not apply to you.

Legal Rights: This warranty gives you specific legal rights, and you may also have other rights which vary from state to state.