

# QUEST 746

For complete product  
information, scan here:



- + Industry-Leading Efficiency
- + Wider Dewpoint Performance
- + Superior MERV-13 Air Filtration
- + Patented M-CoRR™ Technology
- + Integrated Lift and Hang Points
- + Auto-Restart After Power Outages

Model Number #4046320

Serial Number

Install Date

Sold By



Patents: [thermastor.com/patents](http://thermastor.com/patents)



## TABLE OF CONTENTS

Safety Precautions .....	2	8. Error Codes .....	18
1. Intended Application.....	3	9. Decommissioning .....	19
2. Registrations .....	3	9.1 Labeling Decommissioned Machines .....	19
3. Specifications.....	3	9.2 Refrigerant Recovery .....	19
4. Installation .....	4	10. Wiring Diagram .....	21
4.1 Location .....	4	Service Parts List .....	23
4.2 Electrical Requirements .....	4	Optional Parts List .....	23
4.3 Condensate Water Removal .....	5	Warranty .....	24
4.4 Hanging Diagram .....	6		
4.5 Ducting .....	7		
5. Control Options .....	9		
5.1 Onboard Control .....	9		
5.2 External Controls .....	10		
5.2A Wiring .....	11		
5.2B Daisy Chain .....	12		
6. Maintenance .....	13		
6.1 Standard Air Filter .....	13		
7. Service .....	13		
7.1 Warranty .....	13		
7.2 Technical Description .....	13		
7.3 Service Personnel .....	13		
7.4 Checks to Electrical Devices .....	14		
7.5 Repairs to Sealed Component .....	15		
7.6 Repairs to Intrinsically Safe Components .....	15		
7.7 Detection of Flammable Refrigerants .....	15		
7.8 Refrigerant Removal and Evacuation .....	16		
7.9 Charging Procedures .....	16		
7.10 Troubleshooting .....	16		



4201 Lien Rd. Madison, WI 53704 | 1-877-420-1330  
 Thermastor.com | QuestClimate.com

## SAFETY PRECAUTIONS

Read the installation, operation and maintenance instructions carefully before installing and operating this device. Proper adherence to these instructions is essential to obtain maximum benefit from your Quest dehumidifier.

### READ AND SAVE THESE INSTRUCTIONS

- » The device is designed to be installed INDOORS IN A SPACE THAT IS PROTECTED FROM RAIN AND FLOODING.
- » Install the unit with space to access the back or side panels for maintenance and service. **DO NOT INSTALL UNIT WITH THE SERVICE PANELS INACCESSIBLE.**
- » Avoid directing the discharge air at people, or over the water in pool areas.
- » If used near a pool, spa or water: be certain there is NO chance the unit could fall into the water, be splashed, and that it is plugged into an outlet that is a **GROUND FAULT INTERRUPT protected circuit.**
- » DO NOT use the device as a bench or table.
- » DO NOT place the device directly on structural members. Provide vibration isolation in order to minimize operational vibration and/or noise.
- » A drain pan **MUST** be placed under the unit if installed above a living area or above an area where water leakage could cause damage.
- » Never operate a unit with a damaged power cord. If the power cord is damaged it must be replaced by the manufacturer, its service agent, or similarly qualified person in order to avoid a hazard.
- » Make all electrical connections in accordance with the current edition of the NEC ANSI/NFPA 70 and any national and local codes or ordinances that may apply.
- » Maintain a minimum 3 ft (1m) clearance to avoid obstructing the air return and supply.
- » This appliance is not intended for use by persons (including children) with reduced physical, sensory or mental capabilities, or lack of experience and knowledge, unless they have been given supervision or instruction concerning use of the appliance by a person responsible for their safety. Children should be supervised to ensure that they do not play with the appliance.
- » Not intended for use at altitudes over 6500 ft (2000M).



**WARNING** Do not use means to accelerate the defrosting process or to clean, other than those recommended by the manufacturer.

The appliance shall be stored in a room without continuously operating ignition sources (for example: open flames, an operating gas appliance, or an operating electric heater.

Do not pierce or burn. Be aware that refrigerants may not contain an odor.



**REFRIGERANT  
SAFETY GROUP  
A2L**

### 1. INTENDED APPLICATION FOR QUEST 746

The Quest 746 Dehumidifier is designed to operate in temperatures between 56 F and 95 F.

In order to efficiently control humidity levels, the area in which the dehumidifier is to be operated must be free of water intrusion or excessive fresh (outside) air infiltration. Before installing the Quest 746 Dehumidifier, water intrusion and air infiltration problems should be addressed or noted in calculations.

### 2. REGISTRATIONS

The Quest 746 Dehumidifier units conform to unified standards: UL 60335-2-40, CSA 22.2 # 60335-2-40:2012 Ed. 1+4. Patent: [thermastor.com/patents](http://thermastor.com/patents)

### 3. SPECIFICATIONS @ 80°F / 60% RH

UNIT	QUEST 746 4046320	
CFM:	1,650 @ 0.0" WG	
POWER:	3,665 Watts	
SUPPLY VOLTAGE:	480 VAC 3 Phase - 60 Hz	
CURRENT DRAW:	4.9A	
RATED CURRENT DRAW: (104 F   36%)	6.0A	
MCA *	15A	
MOP *	15A	
RECOMMENDED BREAKER SIZE:	15A	
OPERATING TEMP:	56 F Min - 95 F Max	
WATER REMOVAL (PINTS/DAY):	730	
EFFICIENCY (PINTS/KWH):	8.3	
ENERGY FACTOR (L/KWH):	3.9	
AIR FILTER: (QTY 2)	MERV-13: 18" x 20" x 2"	
POWER CORD:	No cord; hardwire only	
ELECTRICAL KNOCKOUT SIZE:	3/4" (1.094" opening)	
DRAIN CONNECTION:	3/4" Threaded NPT	
REFRIGERANT TYPE:	R454B	
REFRIGERANT AMOUNT:	6 lb 8 oz	
DIMENSIONS:	Unit	Shipping
LENGTH:	44.7"	47"
WIDTH:	29.0"	33"
HEIGHT:	27.4"	28"
WEIGHT:	300 lb	360 lb

**\* MCA = Minimum Circuit Ampacity**

This number provides a qualified electrician with the information needed to determine the minimum wire size used in the circuit that feeds a single dehumidifier.

**\* MOP = Maximum Overcurrent Protection**

This number provides a qualified electrician with the value of the maximum size circuit breaker that may be used to protect the circuit that feeds a dehumidifier.

**NOTE:** Specifications are subject to change without notice.

## 4. INSTALLATION

### 4.1 LOCATION

The Quest 746 Dehumidifier can be installed in a variety of locations to meet the owner’s needs as listed below. In all cases keep the following cautions in mind:

- » The minimum floor area of the room shall be 63.4m<sup>2</sup> or 682.4ft<sup>2</sup> at sea level. To establish minimum room area at different altitude, multiply 63.4m<sup>2</sup> by altitude adjustment factor.

H <sub>alt</sub> m	0	200	400	600	800	1000
H <sub>alt</sub> ft	0	656	1312	1969	2625	3281
Factor	1	1	1	1	1.02	1.05
H <sub>alt</sub> m	1000	1200	1400	1600	1800	2000
H <sub>alt</sub> ft	3281	3937	4593	5249	5906	6562
Factor	1.05	1.07	1.1	1.12	1.15	1.18

- » Per 60335-2-40 Edition 4 Table GG, minimum airflow is 800CFM.
- » Ducts connected to the dehumidifier shall not contain a POTENTIAL IGNITION SOURCE.
- » Supply and return air shall be directly ducted to the space. Open areas such as false ceilings shall not be used as a return air duct.
- » The refrigerant detection sensor automatically operates in the event of a detected refrigerant leak and triggers the fan to ventilate. Refrigerant detection sensor shall only be replaced with sensor specified by Therma-Stor.

#### Unventilated Areas

- » Unventilated Areas where the Quest 746 is installed or stored need to be so constructed that should any refrigerant leak, it will not stagnate so as to create a fire or explosion hazard.
- » The Quest 746 shall only be installed and/or stored in a room 35.5 m<sup>3</sup> (1250 ft<sup>3</sup>) or larger.
- » Quest 746 shall not be stored or ducted into one or multiple rooms with continuously operating open flames (for example an operating gas appliance) or other POTENTIAL IGNITION SOURCES (for example an operating electric heater, hot surfaces). A flame-producing device may be installed in the same space if the device is provided with an effective flame arrest.
- » If the Quest 746 is ducted to one or more rooms, Auxiliary devices which may be a POTENTIAL IGNITION SOURCE shall not be installed in the duct work. Examples of such POTENTIAL IGNITION SOURCES are hot surfaces with a temperature exceeding 500°C and electric switching devices.
- » The Quest 746 shall be stored so as to prevent mechanical damage from occurring.

### 4.2 ELECTRICAL REQUIREMENTS

#### High Voltage Connections

The Quest 746 dehumidifier must be wired directly to the electrical service. The current draw under normal operating conditions is listed in section 3.

Information required for proper electrical service installation and overcurrent protection may be found on the dehumidifier nameplate. The unit power switch is a disconnect switch. Route power and ground wires through the electrical knockout hole. Electrical input power wiring must comply with all national, state, and local electrical codes. Make electrical connections according to the wiring diagram provided in this manual and inside the access panel of the Dehumidifier. A ground fault interrupter protected circuit is recommended.

**Low Voltage Connections**

Install the external control in a central area of the structure where it will sense the relative humidity accurately. Avoid installing the sensor near HVAC supply registers, near exterior doors, or near pool or spa. The installer must supply the wiring between the Dehumidifier and the control panel. Be sure to safely route the control wiring to prevent damage during installation. Be careful not to cross the wires when connecting the Dehumidifier and the Control.

The controls of the Dehumidifier are powered by a low voltage circuit (24VAC) and must NEVER contact or be connected to a high voltage circuit. The control terminals are labeled to prevent confusion. For more information on controls, see section 5.

**⚠️ WARNING!** Electrical Shock Hazard: Electrical power must be present for some tests. These tests should be performed by a qualified service person.

**4.3 CONDENSATE WATER REMOVAL**

Condensate drains by gravity via the drain port. Use 3/4" male NPT PVC pipe. An optional condensate pump kit may be installed if a lift is required to dispose of the condensate. Optional parts list for information on the kit.

**FOLLOW DIAGRAM:**

Level unit within 2°

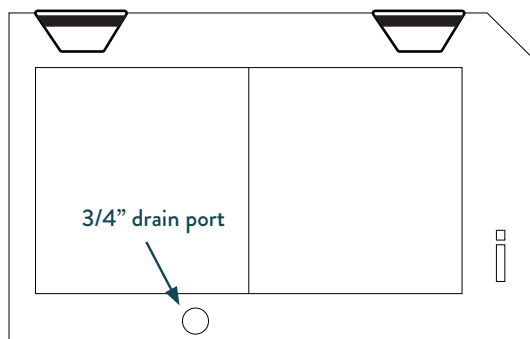

**DRAIN TRAP REQUIRED:**

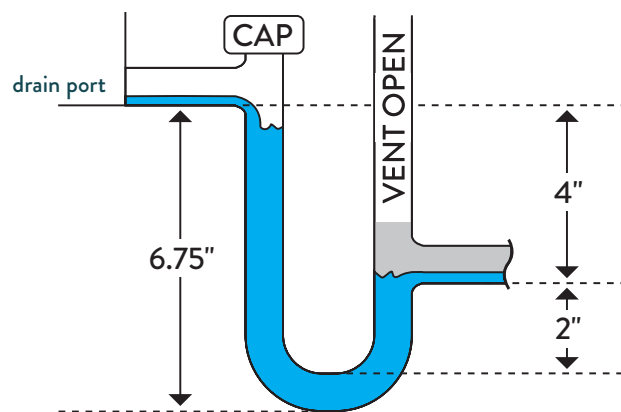

4.4 HANGING DIAGRAM

**⚠ WARNING!** Hanging installation must meet all state and local codes.

**⚠ WARNING!** Installation should be done by a qualified agency in accordance with these instructions. The qualified service agency installing this high efficiency refrigeration system is responsible for the installation.

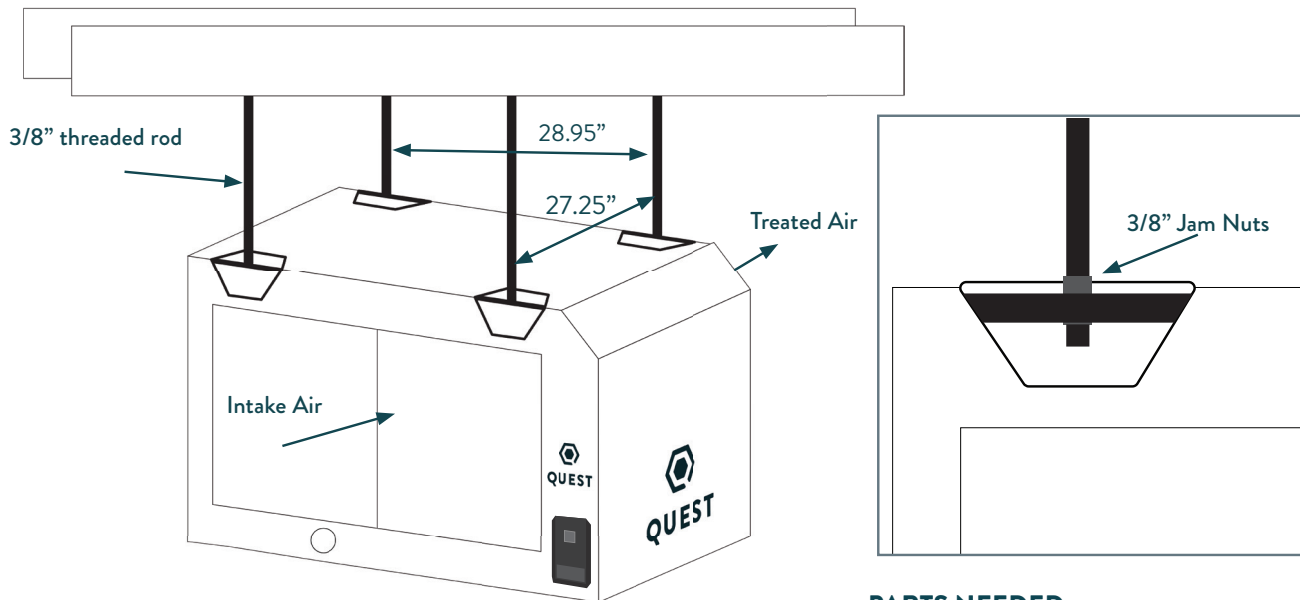

**PARTS NEEDED:**

- 4 pieces 3/8" threaded rod (not included)
- 4 - 3/8" threaded jam nuts (not included)

**⚠ WARNING!** Check the supporting structure to be used to verify that it has sufficient load carrying capacity to support the weight of the unit. Suspend the unit only from the threaded nut retainers. Do NOT suspend from the cabinet.

**⚠ CAUTION!** Recommended maximum hanger rod is 6 ft (1.8 m).

### 4.5 DUCTING GUIDANCE

**⚠ CAUTION!** Quest 746 is intended for use in statics under .5"WG.

- » Ducting the intake and exhaust requires rectangular ducting, dimensions shown below. Custom Therma-Stor duct accessory kits below are recommended.
- » Grills or diffusers on the duct ends must not excessively restrict airflow.
- » Effective dehumidification may require ducting to be branched to isolated or stagnant flow areas. Be sure to use appropriate size duct branches to maintain proper feed throughout the ducting system.
- » System control should be placed remotely from the dehumidifier in a central location.
- » Intake and exhaust ducting should have a minimum of 4 feet from the unit before any turns and maximum of 25' for total run.

**⚠ CAUTION!** Do not connect with a static pressure greater than +.5"wg. Contact technical support for additional details.

- **Optional duct kits are available:** Exhaust Kit #4044431 and Intake Kit #4044432. See figures below for plenum dimensions. Alternatively, licensed contractors can fabricate duct plenums and reference figures below for safe fastener mounting points.

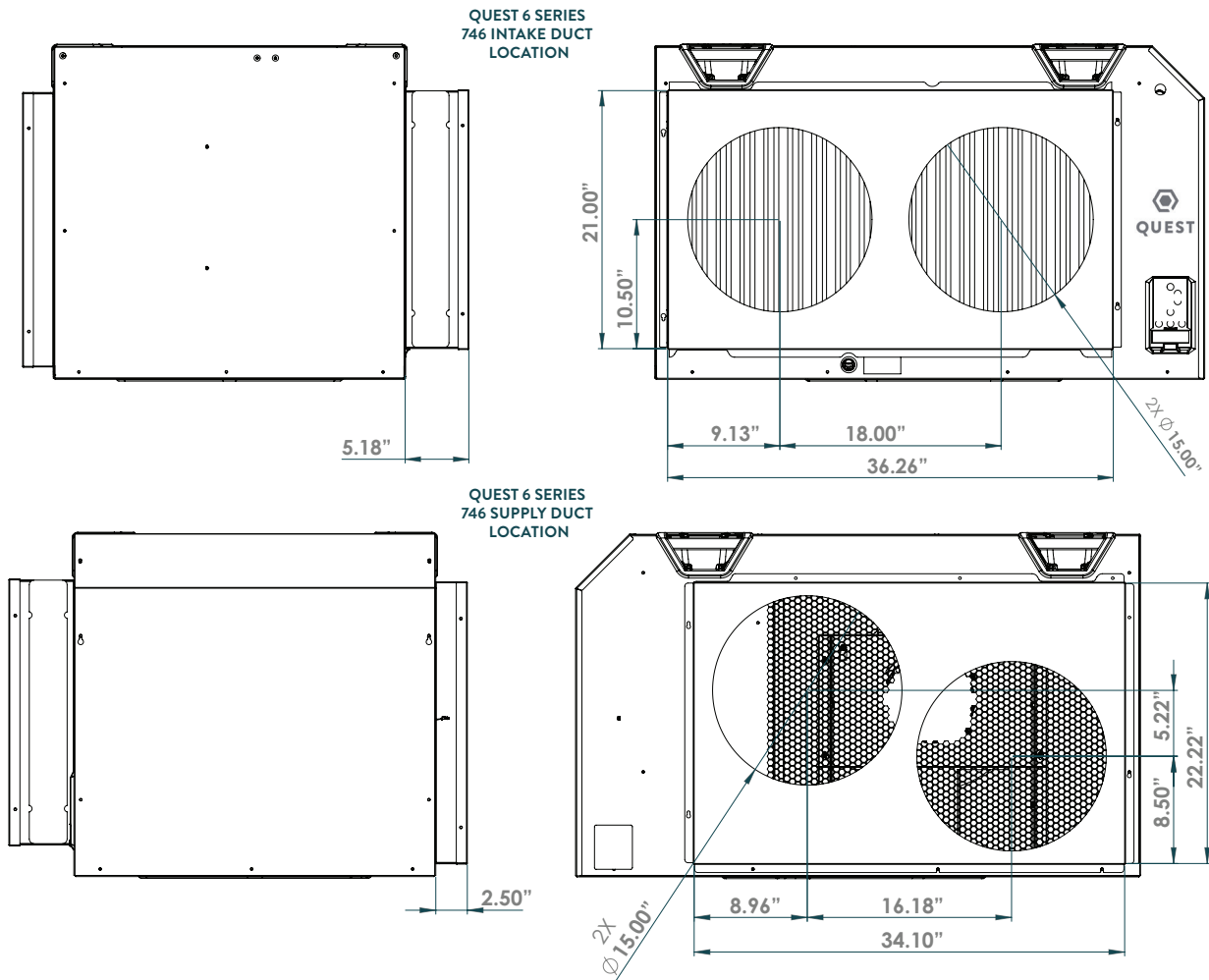

If owner chooses to have a licensed HVAC contractor fabricate a duct kit, please follow the drawing below for safe zones for self tapping screws.

**INTAKE SIDE**

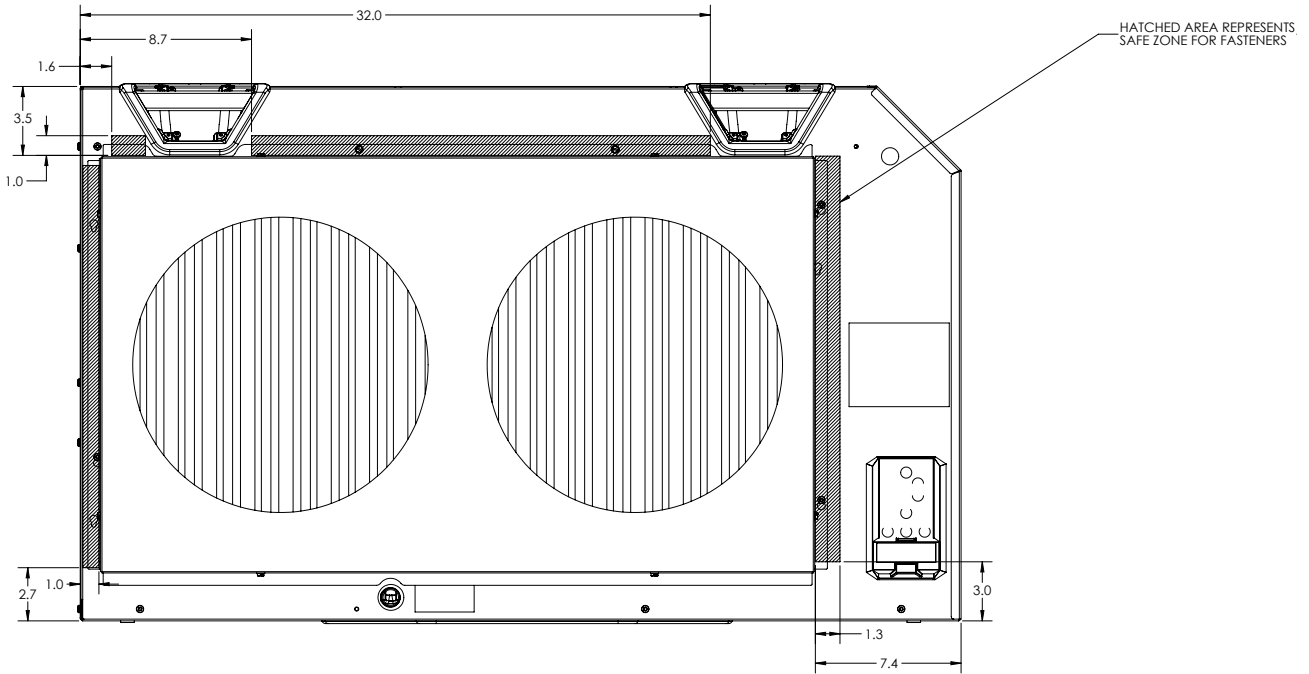

**EXHAUST SIDE**

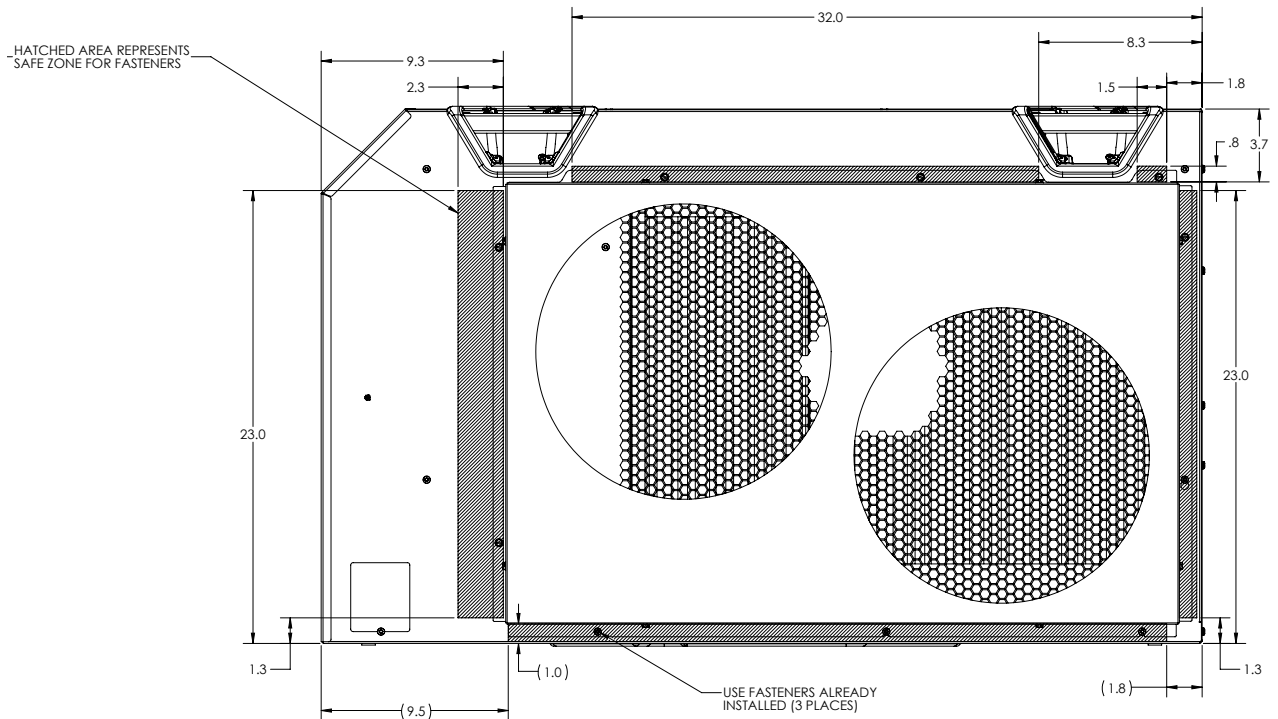

## 5. CONTROL OPTIONS

The Quest 746 Dehumidifier may be controlled by onboard controls or an external remote humidistat through a 24v terminal block. External control NOT provided.

### 5.1 ONBOARD CONTROL

**Off Mode:** Fan, Compressor, Display, and all LEDS are off

**Turn Unit ON:** Press the Power button

**On Mode:** Display is on and shows the RH set point (initial set point: 55% RH)

**To Change Set Point:**

- » Press the up or down arrow once, the 2-digit display will begin to blink.
- » Adjust to desired relative humidity. Each push of the button will change the SP 1% RH.
- » After 6 seconds without a button being pushed, the number showing will become the new set point



### DEFROST LIGHT

- » The light over the snowflake will light up when defrost is occurring (ice is detected on coils). The fan will be on, and the compressor will be off during defrost.



### FILTER RESET

- » Filter reset button will light up after the fan has been running for 2,000 hours, or if the pressure switch detects excessive pressure build-up indicating that the filter must be changed.
- » After changing the filter, press and hold the filter reset button to reset the 2,000-hour timer. Light flashes while button is held.



### DARK MODE

- » Press the Dark Mode button to activate Dark Mode.
- » Once Dark Mode is activated, lights will remain on for 20 seconds before the unit's hygostat will go dark. Dark Mode light will flash for 3 seconds before unit goes dark.
- » Unit will temporarily leave dark mode when any button is pushed and will go dark 20 seconds after the last button is pushed.
- » To turn off Dark Mode, press the Dark Mode button and ensure light above Dark Mode button is off.
- » This mode is for applications where the user would like the unit to operate without emitting any light.



### FAN

Pressing the Fan button alternates the Fan running with the compressor and Fan always on. Make sure the wire jumper on the low voltage terminal block is moved from FAN-to-24V COM to FAN-to-24VAC.



### TERMINAL CONTROL

- » When the **Terminal Control** button is pressed, the display will show "tc".
- » The **Terminal Control** button is used to activate the "DEHUM" input on the terminal block.
- » This must be activated when an external control is used to control RH. When Terminal Control is active, the internal RH sensor is disabled.

## 5.2 EXTERNAL CONTROL OPTIONS

A 24VAC signal is sent by the remote humidistat signals the fan or fan and compressor to actuate.

### Quest offers two external control options:

- » DEH 3000R
- » Honeywell Humidistat

Other options: Any 24V signal to dehumidify, such as Trolmaster.

### 5.2A WIRING EXTERNAL CONTROL

The terminal block, low voltage circuit breaker, and onboard controls are located on the intake side of the unit. Disconnect power while wiring the unit.

**⚠ CAUTION!** Low Voltage Hazard. Can cause equipment damage. Disconnect power before beginning installation.

Remove the cover from the bottom of the user interface to expose the terminal block inputs and outputs.

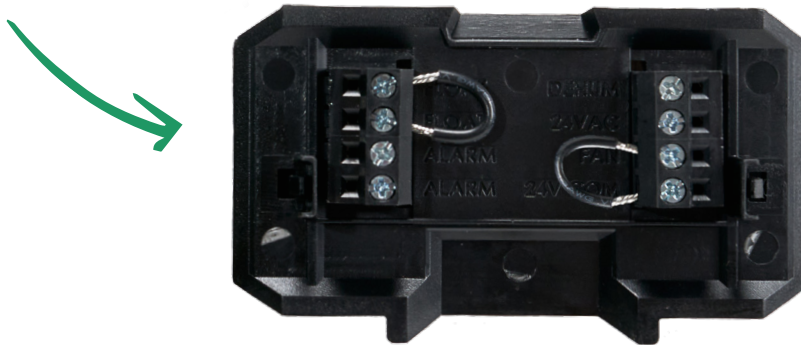

To order a controller, contact your dealer, call 1-877-420-1330, or go to: [www.questclimate.com/product-category/accessories](http://www.questclimate.com/product-category/accessories)

PN 4028531  
QUEST DEH 3000R CONTROL  
WIRING DIAGRAM

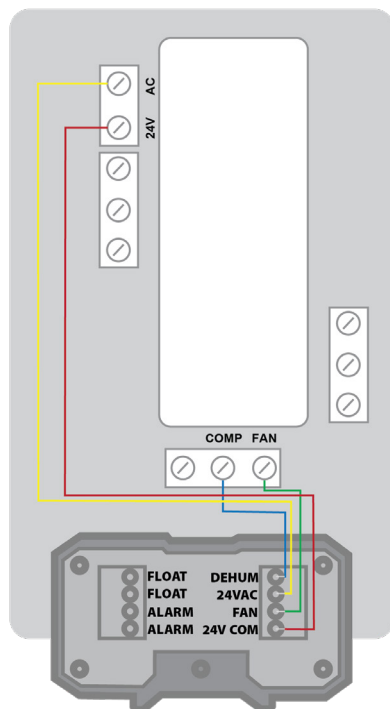

PN 4041649  
HONEYWELL HUMIDIPRO  
WIRING DIAGRAM

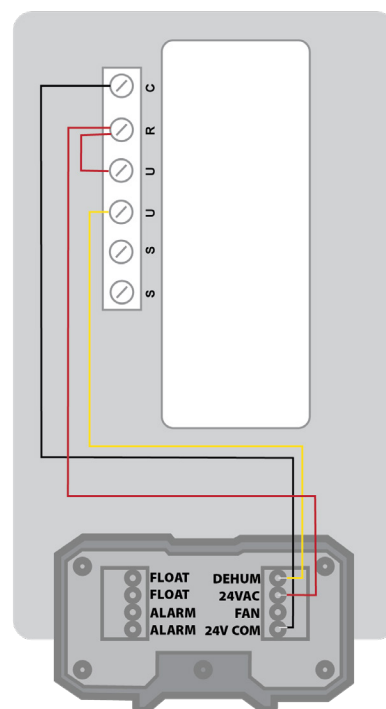

**NOTE:** 22ga wire needed for sensor.

5.2B DAISY CHAIN

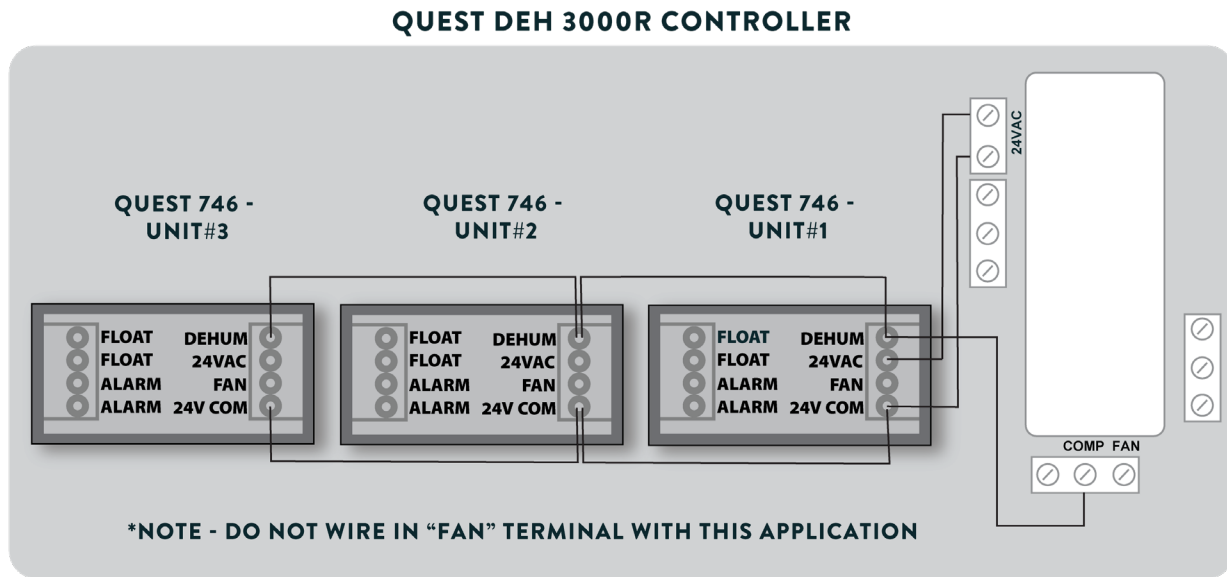

**QUEST 746 TERMINAL BLOCK CONTROL OPERATIONS:**

- DEHUM:** Dehumidification (Fan and Compressor) Control Input.
- 24VAC:** Transformer High Side Output to External Control.
- Fan:** Fan Control Input.
- 24V COM:** 24VAC Power Transformer Neutral Side Output to External Control.
- FLOAT:** External Low Voltage Float Switch or Water Sensor Input (Use Normally Closed Switch).
- FLOAT:** External Low Voltage Float Switch or Water Sensor Input (Use Normally Closed Switch).
- Alarm:** Normally Closed Relay Output - Indicates when dehumidifier is in an alarm state.
- Alarm:** Normally Closed Relay Output - Indicates when dehumidifier is in an alarm state.

**NOTE:** Alarm terminals are used to interface with a remote alarm or building automation system. The terminals switch when the unit has a malfunction and are factory set to “normally closed” but can be changed to “normally open”.

## 6. MAINTENANCE

**⚠ WARNING!** Do not operate the unit without the filter or with a less effective filter. Filter non-compliance invalidates the product warranty.

### 6.1 STANDARD AIR FILTER

The Quest 746 Dehumidifier ships with two standard MERV 13 efficient pleated fabric filters. This filter should be checked every six months. Operating the unit with a dirty filter will reduce dehumidifier capacity and efficiency.

To access the air filter, the filter should be readily visible and can be removed by pulling it straight out of the Quest 746 Dehumidifier.

For agriculture, we recommend changing the filter with every grow cycle.

## 7. SERVICE

**⚠ WARNING!** Servicing the Quest 746 with its high pressure refrigerant system and high voltage circuitry presents a health hazard which could result in death, serious bodily injury, and/or property damage. Only qualified service personnel should service this unit.

### 7.1 WARRANTY

A warranty certificate has been enclosed with this unit; read it before any repair is initiated. If a warranty repair is required, call the factory first at 1-877-420-1330 for warranty claim authorization and technical assistance.

### 7.2 TECHNICAL DESCRIPTION (NON STANDARD PATENTED)

The Quest 746 Dehumidifier uses a refrigeration system to remove moisture from incoming air, and add heat to the air that is discharged.

Hot, high-pressure refrigerant gas is routed from the compressor to the condenser coil. The refrigerant is cooled and condensed by giving up its heat to the air that is about to be discharged from the unit. The refrigerant liquid then passes through a filter/drier and expansion drier which causes the refrigerant pressure and temperature to drop. It next enters the evaporator coil where the cool refrigerant absorbs heat from the incoming air and evaporates.

The compressor evacuates the cool refrigerant vapor from the evaporator and compresses it to a high pressure and temperature to repeat the process.

### 7.3 SERVICE PERSONNEL

Only qualified HVAC or electrical contractors are allowed to conduct maintenance, service and/or repair operations on Quest 746 machines. Examples include but are not limited to breaking into the refrigerating circuit, opening of sealed components, and/or opening of ventilated enclosures.

Prior to beginning work on the Quest 746 machine, safety checks are necessary to ensure that the risk of ignition is minimized.

- » For repair to the REFRIGERATING SYSTEM, a qualified contractor should first establish a controlled procedure so as to minimize the risk of a flammable gas or vapor being present while the work is being performed.

- » All maintenance staff and others working in the local area shall be instructed on the nature of work being carried out. Work in confined spaces shall be avoided.
- » The area shall be checked with an appropriate refrigerant detector prior to and during work, to ensure the technician is aware of potentially toxic or flammable atmospheres. Ensure that the leak detection equipment being used is suitable for use with all applicable refrigerants, i.e. non-sparking, adequately sealed or intrinsically safe.
- » If any hot work is to be conducted on the refrigerating equipment or any associated parts, appropriate fire extinguishing equipment shall be available to hand. Have a dry powder or CO2 fire extinguisher adjacent to the charging area
- » No person carrying out work in relation to a REFRIGERATING SYSTEM which involves exposing any pipe work shall use any sources of ignition in such a manner that it may lead to the risk of fire or explosion. All possible ignition sources, including cigarette smoking, should be kept sufficiently far away from the site of installation, repairing, removing and disposal, during which refrigerant can possibly be released to the surrounding space. Prior to work taking place, the area around the equipment is to be surveyed to make sure that there are no flammable hazards or ignition risks. "No Smoking" signs shall be displayed.
- » Ensure that the area is in the open or that it is adequately ventilated before breaking into the system or conducting any hot work. A degree of ventilation shall continue during the period that the work is carried out. The ventilation should safely disperse any released refrigerant and preferably expel it externally into the atmosphere.

**The following checks shall be applied to installations using FLAMMABLE REFRIGERANTS:**

- » Where electrical components are being changed, they shall be fit for the purpose and to the correct specification. At all times Therma-Stor's maintenance and service guidelines shall be followed. If in doubt, consult Therma-Stor's technical department for assistance.
- » The actual REFRIGERANT CHARGE is in accordance with the room size within which the refrigerant containing parts are installed.
- » the ventilation machinery and outlets are operating adequately and are not obstructed.
- » Marking to the equipment continues to be visible and legible. Markings and signs that are illegible shall be corrected.
- » Dehumidifiers are installed in a position where they are unlikely to be exposed to any substance which may corrode refrigerant containing components, unless the components are constructed of materials which are inherently resistant to being corroded or are suitably protected against being so corroded.

## 7.4 CHECKS TO ELECTRICAL DEVICES

Repair and maintenance to electrical components shall include initial safety checks and component inspection procedures. If a fault exists that could compromise safety, then no electrical supply shall be connected to the circuit until it is satisfactorily dealt with. If the fault cannot be corrected immediately but it is necessary to continue operation, an adequate temporary solution shall be used. This shall be reported to the owner of the equipment so all parties are advised.

**Initial safety checks shall include:**

- that capacitors are discharged: this shall be done in a safe manner to avoid possibility of sparking.
- that no live electrical components and wiring are exposed while charging, recovering or purging the system.
- that there is continuity of earth bonding.

## 7.5 REPAIRS TO SEALED COMPONENTS

- » During repairs to sealed components, all electrical supplies shall be disconnected from the equipment being worked upon prior to any removal of sealed covers, etc. If it is absolutely necessary to have an electrical supply to equipment during servicing, then a permanently operating form of leak detection shall be located at the most critical point to warn of a potentially hazardous situation.
- » Particular attention shall be paid to the following to ensure that by working on electrical components, the casing is not altered in such a way that the level of protection is affected. This shall include damage to cables, excessive number of connections, terminals not made to original specification, damage to seals, incorrect fitting of glands, etc.
- » Ensure that the equipment is mounted securely.
- » Ensure that seals or sealing materials have not degraded to the point that they no longer serve the purpose of preventing the ingress of flammable atmospheres
- » Replacement parts shall be in accordance with Therma-Stor specifications.

## 7.6 REPAIRS TO INTRINSICALLY SAFE COMPONENTS

- » Do not apply any permanent inductive or capacitance loads to the circuit without ensuring that this will not exceed the permissible voltage and current permitted for the equipment in use.
- » Intrinsically safe components are the only types that can be worked on while live in the presence of a flammable atmosphere. The test apparatus shall be at the correct rating.
- » Replace components only with parts specified by Therma-Stor. Other parts may result in the ignition of refrigerant in the atmosphere from a leak.
- » NOTE The use of silicon sealant can inhibit the effectiveness of some types of leak detection equipment. Intrinsically safe components do not have to be isolated prior to working on them.
- » Check that cabling will not be subject to wear, corrosion, excessive pressure, vibration, sharp edges or any other adverse environmental effects. The check shall also take into account the effects of aging or continual vibration from sources such as compressors or fans.

## 7.7 DETECTION OF FLAMMABLE REFRIGERANTS

- » Under no circumstances shall potential sources of ignition be used in the searching for or detection of refrigerant leaks. A halide torch (or any other detector using a naked flame) shall not be used.
- » The following leak detection methods are deemed acceptable for all refrigerant systems:
  - Electronic leak detectors may be used to detect refrigerant leaks but, in the case of FLAMMABLE REFRIGERANTS, the sensitivity may not be adequate, or may need re-calibration. (Detection equipment shall be calibrated in a refrigerant-free area.) Ensure that the detector is not a potential source of ignition and is suitable for the refrigerant used. Leak detection equipment shall be set at 25% LFL of the refrigerant and shall be calibrated to 454B.
  - Leak detection fluids are also suitable for use with most refrigerants but the use of detergents containing chlorine shall be avoided as the chlorine may react with the refrigerant and corrode the copper pipe.

**NOTE EXAMPLES OF LEAK DETECTION FLUIDS ARE:**

- bubble method
  - fluorescent method agents
- » If a leak is suspected, all open flames shall be removed/extinguished.
- » If a leakage of refrigerant is found which requires brazing, all of the refrigerant shall be recovered from the system, or isolated (by means of shut off valves) in a part of the system remote from the leak. Removal of refrigerant shall be according to Clause DD.9 of 60335-2-40.

**7.8 REFRIGERANT REMOVAL AND EVACUATION**

When breaking into the refrigerant circuit to make repairs - or for any other purpose - conventional procedures shall be used. However, for FLAMMABLE REFRIGERANTS it is important that best practice is followed since flammability is a consideration. The following procedure shall be adhered to:

- remove refrigerant
- purge the circuit with inert gas (optional for A2L)
- evacuate (optional for A2L)
- purge with inert gas (optional for A2L)
- open the circuit by cutting or brazing
- The REFRIGERANT CHARGE shall be recovered into the correct recovery cylinders. Compressed air or oxygen shall not be used for purging refrigerant systems.
- Ensure that the outlet for the vacuum pump is not close to any POTENTIAL IGNITION SOURCES and that ventilation is available.

**7.9 CHARGING PROCEDURES**

In addition to conventional charging procedures, the following requirements shall be followed:

- » Ensure that contamination of different refrigerants does not occur when using charging equipment. Hoses or lines shall be as short as possible to minimize the amount of refrigerant contained in them.
- » Cylinders shall be kept in an appropriate position according to the instructions.
- » Ensure that the REFRIGERATING SYSTEM is grounded prior to charging the system with refrigerant.
- » Label the system when charging is complete (if not already).
- » Extreme care shall be taken not to overfill the REFRIGERATING SYSTEM.
- » Prior to recharging the system, it shall be pressure-tested with the appropriate purging gas. The system shall be leak-tested on completion of charging but prior to commissioning. A follow up leak test shall be carried out prior to leaving the site.

**7.10 TROUBLESHOOTING**

**Neither fan nor compressor running. Dehumidification is being called for. No fan call.**

1. Unit unplugged or no power to outlet.
2. Humidity control set too high.
3. Loose connection in internal or control wiring.
4. Defective Compressor relay.
5. Defective control transformer.

**Compressor is not running. Dehumidification is being called for. No fan call.**

1. Defective compressor run capacitor.
2. Loose connection in compressor circuit.
3. Defective compressor overload.
4. Defective compressor.
5. Defrost thermostat open.

**Compressor cycles on and off. Dehumidification is being called for. Fan is running.**

6. Low ambient temperature and/or humidity causing unit to cycle through defrost mode.
7. Defective compressor overload.
8. Defective compressor.
9. Defrost thermostat defective.
10. Dirty air filter(s) or air flow restricted.

**Fan is not running. Dehumidification or fan is being called for.**

1. Loose connection in fan circuit.
2. Obstruction prevents fan impeller rotation.
3. Defective fan.
4. Defective fan relay.

**Low dehumidification capacity (evaporator is frosted continuously). Dehumidification is being called for.**

1. Defrost sensor loose or defective.
2. Low refrigerant charge
3. Dirty air filter(s) or air flow restricted.
4. Excessively restrictive ducting connected to unit.

**Unit removes some water, but not as much as expected.**

1. Air temperature and/or humidity have dropped.
2. Humidity meter and or thermometer used are out of calibration.
3. Unit has entered defrost cycle.
4. Air filter dirty.
5. Defective defrost sensor.
6. Low refrigerant charge.
7. Air leak such as loose cover or ducting leaks.
8. Defective compressor.
9. Restrictive ducting.
10. Optional Condensate Pump Safety Switch open.

**Test to determine if the problem is with the unit or control:**

1. Detach field control wiring connections from unit.
2. Connect the 24V and FAN together; only the impeller fan should run. Disconnect the wires.
3. Connect the 24V and DEHU together; fan should run, Compressor should come on after a short delay.
4. Run the unit for 1 hour in an environment that is greater than a 50 F dew point. The unit should produce water from the drain port.
5. If these tests pass, the unit is working properly. You should check the control and field wiring for problems if the unit is not activating. Check for air restrictions, low temperature, low humidity and refrigerant charge if the unit is not producing water.

A warranty certificate has been enclosed with this unit; read it before any repair is initiated. If a warranty repair is required, call the factory first at 1-877-420-1330 for warranty claim authorization and technical assistance.

## 8. ERROR CODES

MACHINE DISPLAY	NAME	POSSIBLE CAUSE(S)	TROUBLESHOOTING	SERVICE NEEDED
Error code "E1"	RH SENSOR ERROR	1. Broken sensor 2. Unplugged sensor	<ul style="list-style-type: none"> <li>Dehumidifier fan will circulate air for 1 minute.</li> <li>Dehumidifier compressor will activate for 15 minutes.</li> <li>This process will repeat every 15 minutes.</li> </ul>	No Displays E1, but keeps running.
Error code "E2"	LOW DEWPOINT; 24V SHORT	1. Dewpoint below 40°F 2. Off calibration Humidity/Temp sensor	<ul style="list-style-type: none"> <li>Dehumidifier will circulate air for 50 seconds every 15 minutes.</li> <li>Dehumidifier will not operate until incoming air dew point reads above 40°F</li> </ul>	No
Error code "E3"	LOW REFRIGERANT	1. Refrigeration leak 2. Evaporator coil temp too high during extended operation	<ul style="list-style-type: none"> <li>Dehumidifier will go into lock-out mode for 1 hour and then attempt to activate compressor.</li> </ul>	Yes
Error code "E4"	FLOAT SWITCH TRIPPED	1. Tripped float switch 2. 24V is shorted to Common 3. Terminal block unplugged from unit	<ul style="list-style-type: none"> <li>The compressor and fan in the dehumidifier will remain off until the connection is fixed or the water event that activated the switch is resolved.</li> </ul>	Yes
Error code "E5"	COIL TEMPERATURE SENSOR	1. Broken sensor 2. Loose connection	<ul style="list-style-type: none"> <li>Dehumidifier will go into lock-out mode for 1 hour and then activate compressor for 15 minutes</li> <li>After the compressor runs for 15 minutes, the unit will go into defrost mode for 30 minutes.</li> </ul>	No
Error code "E6"	TEMPERATURE TOO HIGH	1. Sensor reading incoming air temp is over 120°F 2. Broken sensor	<ul style="list-style-type: none"> <li>Dehumidifier will circulate air for 15 minutes every hour.</li> <li>Dehumidifier will not operate until incoming air temp sensor reads below 120°F</li> </ul>	No
Error code "E7"	TEMPERATURE TOO LOW	1. Sensor reading incoming air temp is under 40°F 2. Broken sensor	<ul style="list-style-type: none"> <li>Dehumidifier will circulate air for 50 seconds every 15 minutes.</li> <li>Dehumidifier will not operate until incoming air temp reads above 40°F.</li> </ul>	No
Error code "E8"	COMM ERROR	1. There is a cable connection issue 2. Defective power board	<ul style="list-style-type: none"> <li>The power board will continue to run unit using the last settings but changes to operation cannot be made until communication is restored.</li> </ul>	Yes, if operational changes are required.
Error code "E9"	HIGH PRESSURE CUT-OUT	1. High pressure sensor has tripped due to excess pressure in the refrigeration system 2. Incoming air temp is too high	<ul style="list-style-type: none"> <li>Power board will be in system protection mode.</li> </ul>	Yes, if the error persists when operating below 90°F incoming air
E10	NOT IN USE	-	-	-
Error code "E11"	REFRIGERANT LEAK SENSOR	1. Refrigerant leak 2. Bad sensor	<ul style="list-style-type: none"> <li>Check refrigerant charge, If low look for a leak.</li> <li>Look for other combustible gasses in the area. Propane, Natural Gas, Refrigerant.</li> <li>Bad or unplugged sensor</li> </ul>	Yes
Error code "E12"	PHASE MONITOR	1. Power wires in wrong location 2. Voltage issue on one or more power wire	<ul style="list-style-type: none"> <li>Switch locations of any 2 of the 3 power wires.</li> <li>Check for proper voltage on all 3 power wires</li> </ul>	Yes

## 9. DECOMMISSIONING

Before carrying out this procedure, it is essential that the technician is completely familiar with the equipment and all its details. It is recommended good practice that all refrigerants are recovered safely. Prior to the task being carried out, an oil and refrigerant sample shall be taken in case analysis is required prior to re-use of recovered refrigerant. It is essential that electrical power is available before the task commences.

1. Become familiar with the equipment and its operation.
2. Isolate system electrically.
3. Before attempting the procedure, ensure that:
  - mechanical handling equipment is available, if required, for handling refrigerant cylinders;
  - all personal protective equipment is available and being used correctly;
  - the recovery process is supervised at all times by a competent person;
  - recovery equipment and cylinders conform to the appropriate standards.
4. Pump down refrigerant system, if possible.
5. If a vacuum is not possible, make a manifold so that refrigerant can be removed from various parts of the system.
6. Make sure that cylinder is situated on the scales before recovery takes place.
7. Start the recovery machine and operate in accordance with instructions.
8. Do not overfill cylinders (no more than 80 % volume liquid charge).
9. Do not exceed the maximum working pressure of the cylinder, even temporarily.
10. When the cylinders have been filled correctly and the process completed, make sure that the cylinders and the equipment are removed from site promptly and all isolation valves on the equipment are closed off.
11. Recovered refrigerant shall not be charged into another REFRIGERATING SYSTEM unless it has been cleaned and checked.

### 8.1 LABELING DECOMMISSIONED MACHINES

Equipment shall be labelled stating that it has been de-commissioned and emptied of refrigerant. The label shall be dated and signed. For appliances containing FLAMMABLE REFRIGERANTS, ensure that there are labels on the equipment stating the equipment contains FLAMMABLE REFRIGERANT.

### 8.2 REFRIGERANT RECOVERY

When removing refrigerant from a system, either for servicing or decommissioning, it is recommended good practice that all refrigerants are removed safely.

- » When transferring refrigerant into cylinders, ensure that only appropriate refrigerant recovery cylinders are employed. Ensure that the correct number of cylinders for holding the total system charge is available. All cylinders to be used are designated for the recovered refrigerant and labelled

for that refrigerant (i.e. special cylinders for the recovery of refrigerant). Cylinders shall be complete with pressure-relief valve and associated shut-off valves in good working order. Empty recovery cylinders are evacuated and, if possible, cooled before recovery occurs.

- » The recovery equipment shall be in good working order with a set of instructions concerning the equipment that is at hand and shall be suitable for the recovery of all appropriate refrigerants including, when applicable, FLAMMABLE REFRIGERANTS. In addition, a set of calibrated weighing scales shall be available and in good working order. Hoses shall be complete with leak-free disconnect couplings and in good condition. Before using the recovery machine, check that it is in satisfactory working order, has been properly maintained and that any associated electrical components are sealed to prevent ignition in the event of a refrigerant release. Consult manufacturer if in doubt.
- » The recovered refrigerant shall be returned to the refrigerant supplier in the correct recovery cylinder, and the relevant waste transfer note arranged. Do not mix refrigerants in recovery units and especially not in cylinders.
- » If compressors or compressor oils are to be removed, ensure that they have been evacuated to an acceptable level to make certain that FLAMMABLE REFRIGERANT does not remain within the lubricant. The evacuation process shall be carried out prior to returning the compressor to the suppliers. Only electric heating to the compressor body shall be employed to accelerate this process. When oil is drained from a system, it shall be carried out safely.

# WIRING DIAGRAM

## QUEST 746 DEHUMIDIFIER

P/N 4043709  
Rev. A

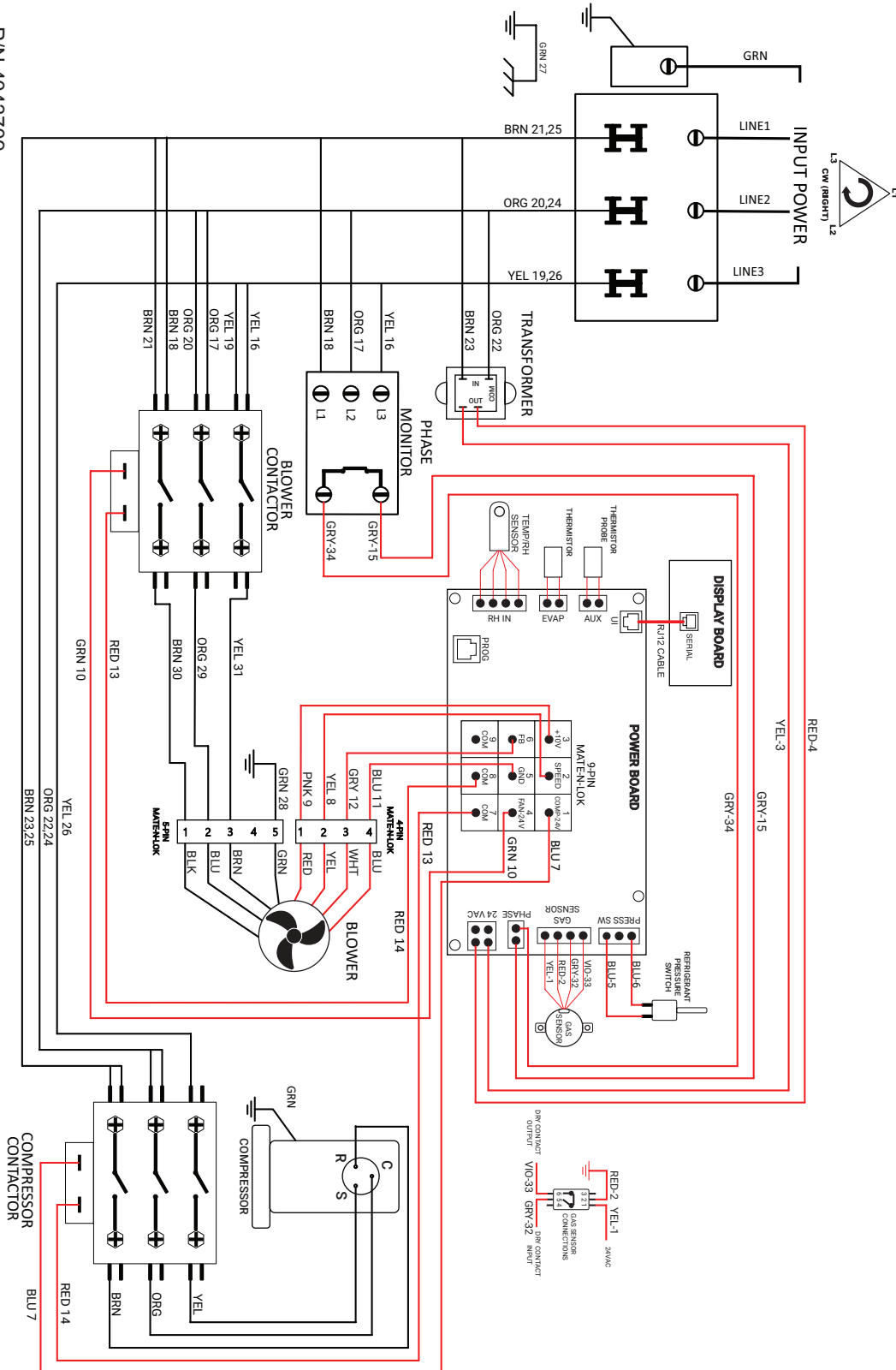

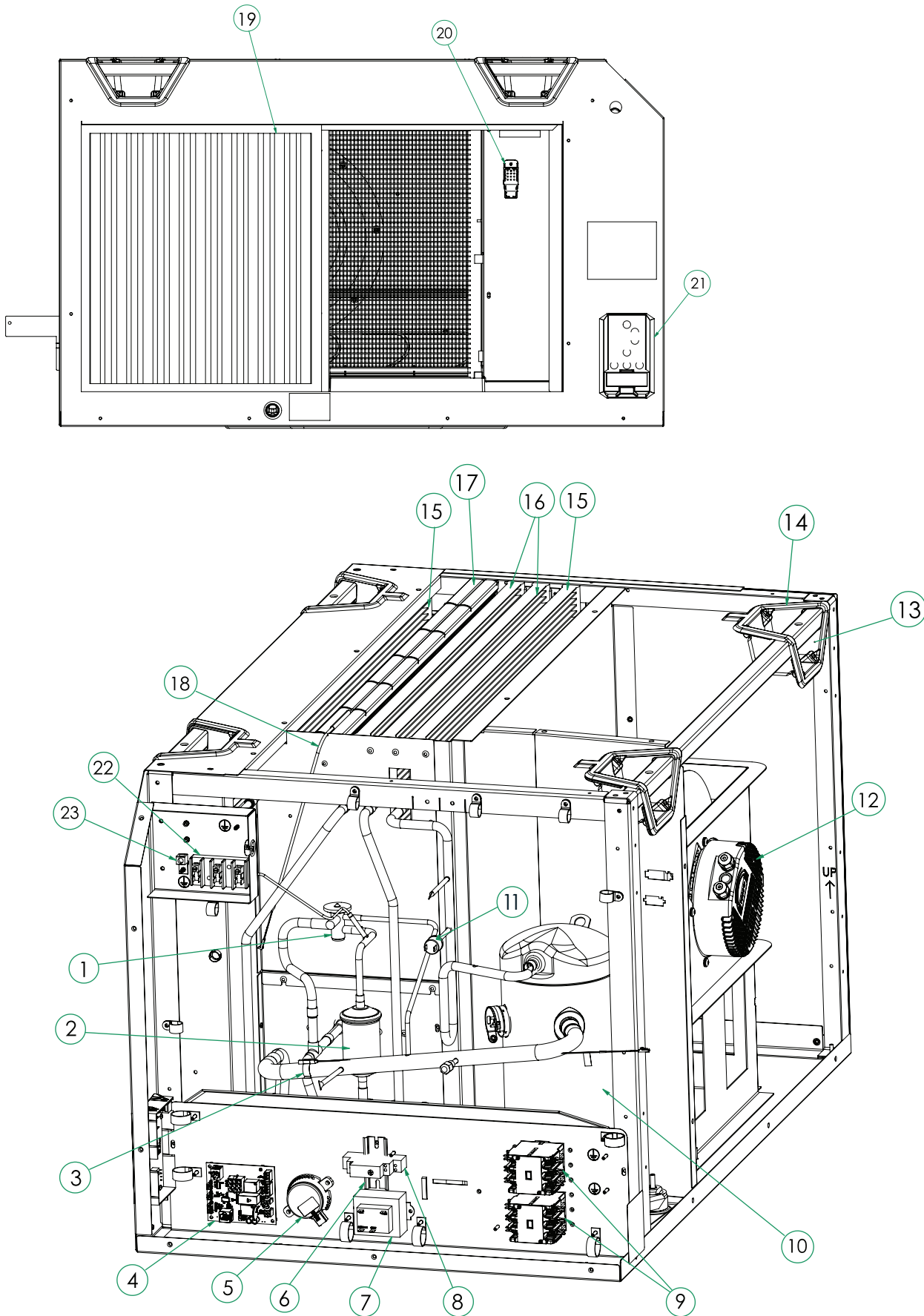

## SERVICE PARTS LIST

Item	Part No	Description	Item	Part No	Description
1	4043874	TXV, 12 KW, 746Z	15	4043379-02	COIL,MICROCHANNEL 20MM (QTY 2)
2	4042468	FILTER DRIER	16	4044097-02	COIL,MCHE,2x17MM,1100DIST
3	4044271-01	THERMISTOR CLIP-ON 20"	17	4043773-02	COIL,MICROCHANNEL 20MM,70/30 (QTY 2)
4	4043128	PWR/CNTL ASSY 746z	18	4044269-01	THERMISTOR PROBE, 30"
5	4043841	SENSOR,A2L,454B	19	4038233-01	AIR FILTER 18 x 20 x 2" (QTY 2)
6	4043839	BRKT,DIN RAIL,35MM X 7.5MM X 3.0"	20	4042061	SENSOR, TEMP & RH, DIGITAL
7	4042114	XFMR,480V,60HZ,40VA	21	4041909	DISPLAY ASSY,24VAC
8	4042478	RELAY,PHASE MONITOR	22	4042475	BLOCK,TERMINAL,3 POSITION
9	4042474	CONTACTOR,3-POLE,24VAC,25A	23	4038079	LUG,GROUND,2-14 AWG
10	4043973	CPRSR,COPE,44CC,SCR,454B,480V	<b>Not Pictured</b>		
11	4043292	CONTROL,HIGH PRESSURE,650 PSI	24	4043658	WIRE HARNESS, 746Z
12	4043654	IMPELLER ASSY,355MM,480V	25	4043659	CPRSR WIRE HARNESS, 746Z
13	4038135	HANDLE, POCKET, 6series (QTY 4)	26	4038789-05	CABLE ASSY, RJ12, RVRS, 12"
14	4043828	BEZEL, HANDLE (QTY 4)			

## OPTIONAL PARTS LIST

Part No	Qty	Description
4028531	1	DEH 3000R Control, Remote
4022220	1	Kit, Pump
4044432	1	Kit, Intake Duct
4044431	1	Kit, Exhaust Duct
4038644	1	Drain Trap Kit



**SEE BACK FOR WARRANTY INFORMATION**

## IMPORTANT WARRANTY INFORMATION

### WARRANTOR:

Therma-Stor LLC  
4201 Lien Rd  
Madison, WI 53704  
Telephone: 1-800-533-7533

**WHO IS COVERED:** This warranty extends only to the original end-user of the Quest 746 dehumidifier, and may not be assigned or transferred.

**FIRST YEAR WARRANTY:** Therma-Stor LLC warrants that, for one (1) year the Quest 746 dehumidifier will operate free from any defects in materials and workmanship, or Therma-Stor LLC will, at its option, repair or replace the defective part(s), free of any charge.

**SECOND THROUGH FIFTH YEAR WARRANTY:** Therma-Stor LLC further warrants that for a period of five (5) years, the condenser, evaporator, and compressor of the Quest 746 dehumidifier will operate free of any defects in material or workmanship, or Therma-Stor LLC, at its option, will repair or replace the defective part(s), provided that all labor and transportation charges for the part(s) shall be borne by the end-user.

**END-USER RESPONSIBILITIES:** Warranty service must be performed by a Servicer authorized by Therma-Stor LLC. If the end-user is unable to locate or obtain warranty service from an authorized Servicer, he should call Therma-Stor LLC at the above number and ask for the Therma-Stor LLC Service Department, which will then arrange for covered warranty service. Warranty service will be performed during normal working hours.

The End-user must present proof of purchase (lease) upon request, by use of the warranty card or other reasonable and reliable means. The end-user is responsible for normal care. This warranty does not cover any defect, malfunction, etc. resulting from misuse, abuse, lack of normal care, corrosion, freezing, tampering, modification, unauthorized or improper repair or installation, accident, acts of nature or any other cause beyond Therma-Stor LLC's reasonable control.

**LIMITATIONS AND EXCLUSIONS:** If any Quest 746 Dehumidifier part is repaired or replaced, the new part shall be warranted for only the remainder of the original warranty period applicable thereto (but all warranty periods will be extended by the period of time, if any, that the Quest 746 Dehumidifier is out of service while awaiting covered warranty service).

**UPON THE EXPIRATION OF THE WRITTEN WARRANTY APPLICABLE TO THE QUEST 746 DEHUMIDIFIER OR ANY PART THEREOF, ALL OTHER WARRANTIES IMPLIED BY LAW, INCLUDING MERCHANTABILITY AND FITNESS FOR A PARTICULAR PURPOSE, SHALL ALSO EXPIRE. ALL WARRANTIES MADE BY THERMA-STOR LLC ARE SET FORTH HEREIN, AND NO CLAIM MAY BE MADE AGAINST THERMA-STOR LLC BASED ON ANY ORAL WARRANTY. IN NO EVENT SHALL THERMA-STOR LLC, IN CONNECTION WITH THE SALE, INSTALLATION, USE, REPAIR OR REPLACEMENT OF ANY Quest Dual DEHUMIDIFIER OR PART THEREOF BE LIABLE UNDER ANY LEGAL THEORY FOR ANY SPECIAL, INDIRECT OR CONSEQUENTIAL DAMAGES INCLUDING WITHOUT LIMITATION WATER DAMAGE (THE END-USER SHOULD TAKE PRECAUTIONS AGAINST SAME), LOST PROFITS, DELAY, OR LOSS OF USE OR DAMAGE TO ANY REAL OR PERSONAL PROPERTY.**

Some states do not allow limitations on how long an implied warranty lasts, and some do not allow the exclusion or limitation of incidental or consequential damages, so one or both of these limitation may not apply to you.

**LEGAL RIGHTS:** This warranty gives you specific legal rights, and you may also have other rights which vary from state to state.

SERIAL  
NUMBER



PART  
NUMBER



PLACE LABEL HERE



### REGISTER YOUR NEW DEHUMIDIFIER

using the serial number  
and part number at  
[thermastor.com/  
registration](https://thermastor.com/registration)  
or scan code above

