

Quest PowerDry 4800D Pro E

Installation, Operation and Maintenance Instructions

– Read and Save These Instructions –

This manual is provided to acquaint you with the desiccant dehumidifier so that installation, operation and maintenance can proceed successfully. Ultimate satisfaction depends on the quality of installation and a thorough understanding of this equipment. The dehumidifier is built around tested engineering principles and has passed a thorough inspection for quality of workmanship and function.

Quest PowerDry 4800D Pro E:

- 3032 Pints/day AHAM
- 4800 CFM process airflow
- Dries in temperatures to 140°F
- Reaches dew points as low as -40°F
- 48"W x 120"L x 74"H
- 1600 lbs. (Standard machine weight only)
- 480 volt 3-phase
- 106 full load amps

Water Removal Rates (Pints/Day)

3032 Pints 80°F, 60% (AHAM)



Quest PowerDry 4800D Pro E (with Frame)

PN 4028203

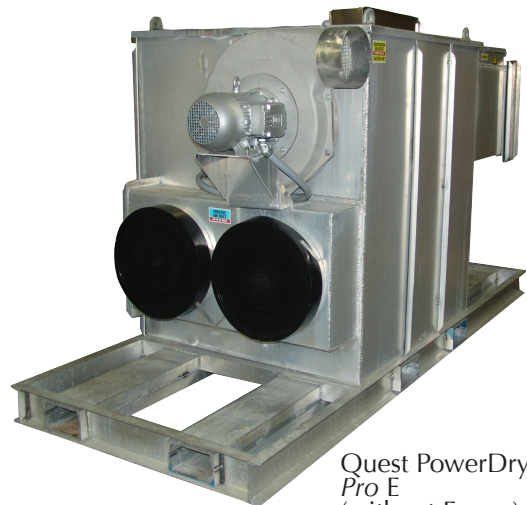

Quest PowerDry 4800D Pro E (without Frame)

PN 4029193



Therma-Stor[®] LLC

Driven by performance. Powered by design.™

4201 Lien Rd.
Madison, WI 53704
www.QuestProtect.com

Phone 608-237-8400
Toll-Free 1-866-933-7486
sales@QuestProtect.com

Table of Contents

Safety Precautions	3	7. Panel Layout/Wiring Diagram.....	12
1. Specifications.....	4	8. Trouble Shooting.....	15
2. Operation	5	9. Detailed Sequence of Events -	
2.1 How the Quest Dry		Control Operation.....	16
PowerDry 4800D Pro E Works	5	10. Service Parts.....	17
3. Installation	5	Warranty.....	18
3.1 Inspection	6	Serial No. _____	
3.2 Location.....	6	Purchase Date _____	
3.3 Set-Up	6	Dealer's Name _____	
3.4 Ducting.....	6	Read the operation and maintenance instructions	
3.5 Avoiding Secondary damage	7	carefully before using this unit. Proper	
3.6 Electrical Requirements.....	7	adherence to these instructions is essential	
4. Operation Instructions.....	7	to obtain maximum benefit from your Quest	
4.1 Connect and Start-Up Procedure.....	8	PowerDry 4800D Pro E.	
4.2 Cool Down	8		
4.3 Shut Down and Disconnect Procedure..	8		
5. Control Panel	8		
5.1 Main Disconnect	8		
5.2 Standby Light	8		
5.3 Phase Out	9		
5.4 Selector Switch	9		
5.5 Alarm.....	9		
5.6 Hour Meter	9		
6. Maintenance.....	9		
6.1 General Maintenance.....	9		
6.2 Cabinet	10		
6.3 Filter	10		
6.4 Blower and Motor	10		
6.5 Drive Motor	10		
6.6 Rotor Drive Chain	10		
6.7 Seals	10		
6.8 Desiccant Media.....	11		



Safety Precautions

Read the installation, operation and maintenance instructions carefully before installing and operating this device. Proper adherence to these instructions is essential to obtain maximum benefit from your Quest PowerDry 4800D Pro E.



1. Specifications

Part No.	4028203 (with Frame)
Part No.	4029193 (without Frame)
Power	480 VAC, 3-Phase, 106 FLA
Water Removal	3032 pints/day @ AHAM
Blower	4800 CFM Process Air Flow 2000 CFM Reactivation Air Flow
Operating Range	-10°F to 140°F
Filters	Process filter size: (2) 20" x 20" x 2" Reactivation filter size: (1) 20" x 20" x 2"
Duct Options	Process inlet/outlet - 18" Heavy Duty PVC minimum, 20" Heavy Duty PVC recommended Reactivation - 18" Heavy Duty PVC minimum, 20" Heavy Duty PVC recommended
Warranty	2 years: 1st year Parts and Service 2nd year Silica Gel Rotor

**Low temperature performance is dependent on reactivation air source. Supplying warmer reactivation air will significantly increase water removal.*

Dimensions

	Unit
Width	48"
Height	74"
Length	120"
Weight	1600 lb

Accessories

4028361	10" Flex-Duct
4028364	18" x 25', 6" Pitch, Heavy Duty PVC/Polyester Duct
4028374	18" Lay Flat Duct
4035579	20" x 25', 4" Pitch, Heavy Duty PVC/Polyester Duct
4024440	Kestrel 3000 Multi-Function Air Meter
4027327	External Temperature control
4020175	External Dehumidistat
4029003	Power Cord Grip
Air Filter Replacement	
4028635	20" x 20" x 2" Filter



2. Operation

The function of the dehumidifier is to remove moisture (in the vapor state) from an air stream. This is accomplished by exposing the air to an adsorbing media (desiccant) in a sealed air stream (process). After the desiccant has adsorbed moisture, it is exposed to a second air stream at an elevated temperature (reactivation). This causes the moisture to be driven out of the desiccant preparing it for more moisture adsorption. This process is done on a continuous basis, providing a constant drying process. The two air streams (process and reactivation) are separated by seals, which contact the desiccant media. Figure 1 illustrates the relationship of the seals and airflow pattern. The dehumidifier is designed with the two air streams flowing in opposite directions (counter flow) thereby maximizing the energy efficiency of the equipment.

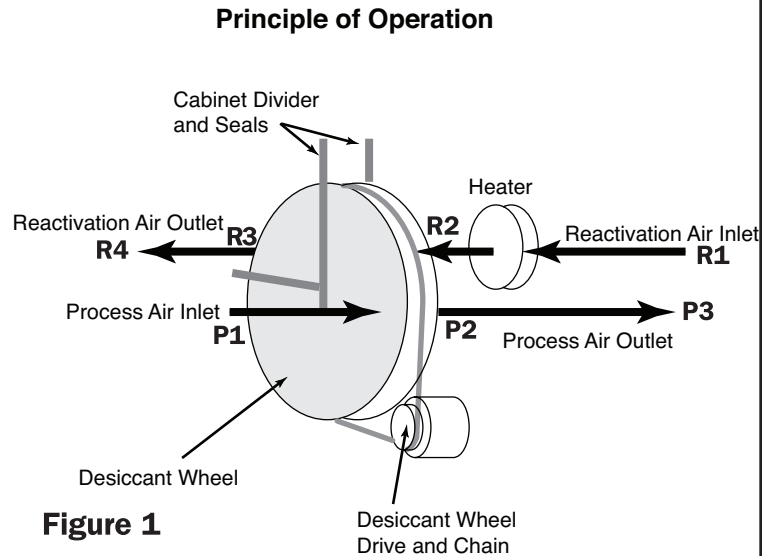

2.1 How the Quest PowerDry 4800D Pro E Works

The Quest PowerDry 4800D Pro E has two separate air streams that run through it – Process and Reactivation (Fig. 1).

Process Air Stream:

P1 – 4800 CFM of air enters the machine (Process Air Inlet) and...

P2 – ...water vapor from incoming air is deposited (adsorbed) on the desiccant wheel.

P3 – 4800 CFM of dry air exits the machine (Process Air Outlet).

Reactivation Air Stream:

R1 – 2000 CFM of air enters the machine (Reactivation Air Inlet) and...

R2 – passes over the heater coils.

R3 – Water vapor is picked up (desorbed) from the desiccant wheel by the hot air and...

R4 – ... 2000 CFM of wet air exits the machine (Reactivation Air Outlet).

3 Installation

Proper installation is critical to the performance of the Quest PowerDry 4800D Pro E. Follow the guidelines below to maximize service life and performance.



3.1 Inspection

Thoroughly inspect the machine to insure no damage has occurred during shipping or on the job site.

3.2 Location

Note the following precautions when locating the Quest PowerDry 4800D Pro E:

The PowerDry 4800D Pro E is designed to be used indoors or outdoors.

If the humid area is very large, dehumidification can be improved by adding an outlet duct to circulate process air to stagnant areas.

3.3 Set-Up

When conditions warrant the use of a desiccant dehumidifier, use one of the setups described below to achieve efficient drying, while avoiding secondary damage. Review Section 2.1 to understand the desiccant drying process. Always ensure that the Reactivation Outlet duct is vented to the outdoors to minimize the possibility of secondary damage.

Neutral Pressure Setup

Many drying applications require neutral pressure operation. In this setup, the Process Air Inlet pulls air from the affected area (drying chamber) and returns dried, processed air to the affected area via the Process Air Outlet.

The Reactivation Air Inlet and Outlet are both ducted to the outdoors (or left open if the unit is set up outside).

Positive Pressure Setup

For Positive Pressure operation, the Process Air Inlet pulls air from outside the drying chamber, while the Process Air Outlet is ducted into the chamber.

3.4 Ducting

The duct requirements of the PowerDry 4800D Pro E are much more critical than those of refrigerant-based dehumidifiers. **ALL SUPPLY AND RETURN AIR DUCTING FOR THE PowerDry 4800D Pro E MUST BE AIR AND VAPOR TIGHT.** This is extremely important for proper performance. Ensure that reactivation discharge air does not enter the process or reactivation inlets.

Using excess duct length significantly reduces air flow volume through duct. This is true in any application. If the job at hand needs a short length of duct, cut a section to the appropriate length. If air flow is restricted by excess length, performance will suffer. The same can be said of excess bends in the ducting.

Two different duct sizes are used on the PowerDry 4800D Pro E. All ducting materials are available from Therma-Stor LLC (see accessories list in Section 1).

Process inlet / Reactivation inlet: 18" flex duct.

To attach flex ducts to the process air intake, push the wire of the first few loops beyond the 2 holes in the duct collar. Push the metal rod through the duct and duct collar piercing the duct in two places. Tape or a hose clamp can be used to create an airtight seal. Alternatively, the duct wire can be pushed past the weld beads on the duct collar and the duct can be secured with hose clamps or ratcheting straps. If using only one inlet connection, the other can be left closed.

Process outlet: 18" flex or lay flat plastic duct.

To attach flex ducts to the process air outlet, push the wire of the first few loops beyond the 2 holes in the duct collar. Push the metal rod through the duct and duct collar piercing the duct in two places. Tape or a hose clamp can be used to create an airtight seal. Alternatively, the duct wire can be pushed past the weld



beads on the duct collar and the duct can be secured with hose clamps or ratcheting straps. When using 18" lay flat ducting, slip over the outlet collar and zip-tie or duct tape in place.

Reactivation outlet: 10" flex duct or lay flat.

To attach flex duct to the reactivation air outlet, push the wire of the first couple of loops beyond the weld beads on an outlet collar. Secure with hose clamp.

3.5 Avoiding Secondary Damage

The Quest PowerDry 4800D Pro E is a powerful tool capable of removing a great deal of water from most environments. Care must be taken to avoid secondary damage of over-drying and or unexpected condensation.

The Quest PowerDry 4800D Pro E removes vapor water from the incoming process air stream and transfers it to the outgoing reactivation air stream. The reactivation exhaust air is hot and wet.

Take care to prevent the reactivation exhaust air stream from causing secondary damage due to condensation. Always ensure the Quest PowerDry 4800D Pro E is located with the reactivation outlet pointed such that reactivation air will NOT be drawn back into the structure.

The Quest PowerDry 4800D Pro E does not produce liquid water internal to the machine. There is no condensate pump and no drain hose.

The Quest PowerDry 4800D Pro E desiccant dehumidifier will continue to remove water from already dry, cold air. It is possible to over-dry objects and or structures.

Care must be taken to avoid secondary damage due to over-drying.

3.6 Electrical Requirements

A 480 volt, 3 phase power source is required to operate the Quest PowerDry 4800D Pro E.

All local and state codes must be strictly adhered to and good electrical practices should be followed to achieve the best installation possible. The PowerDry 4800D Pro E must be properly wired to an adequate power source. Serious damage to the motors and controls can occur if incorrect voltage is applied.

(See **Electrical Schematic** drawing in the back of this manual for internal wiring.)

4 Operating Instructions

Refer to the Operating Instructions label located next to the control panel of your PowerDry 4800D Pro E.

WARNING

User-supplied power cord, cord grip, and branch protection appropriate for the electrical load must be supplied. See device for FLA rating.

The Quest PowerDry 4800D Pro E dehumidifier comes complete and ready for operation. All that is required is to provide the proper power source, propane supply, and duct connections (described above).



4.1 Connect and Start-Up Procedure

1. Lockout Power Source.
2. Wire unit 480 Volt 3 Phase.
3. Verify Selector Switch is set to STANDBY.
4. Engage Power Source and turn Main Disconnect to ON.
5. Verify PHASE OUT light is off, if not, re-wire power source to correct phase order.
6. COOL DOWN light will come on for 5 minutes.
7. Set Selector Switch to RUN.
8. Set process damper to obtain a maximum of 1.5" water column pressure as read on pressure gauge.

4.2 Cool Down

1. Set Selector Switch to STANDBY.
2. COOL DOWN light will come on for 5 minutes.
3. When COOL DOWN light is off, Main Disconnect can be switched to OFF.

Failure to follow **COOL DOWN PROCEDURE** may result in damage to unit due to overheating. **ALWAYS** follow **COOL DOWN PROCEDURE** before shutting unit down.

4.3 Shut Down & Disconnect Procedure

1. Verify COOL DOWN light is not illuminated and Cool Down Procedure has been followed.
2. Turn Main Disconnect Switch to OFF.
3. Disengage Power Source.
4. Lock Out Power Source.
5. Disconnect Power Cable.

5 Control Panel

5.1 Main Disconnect

The main disconnect switches power from the source to the panel. Power must be disconnected at the source prior to accessing control panel. Access to the control panel with power applied is **ONLY** by qualified service personnel with the appropriate personal protective equipment

Power is present up to disconnect even in OFF position. Disconnect power at the source before opening panel.

5.2 Standby Light

The STANDBY indicator lamp illuminates to indicate that power is supplied to the control panel.



5.3 Phase Out

The PHASE OUT indicator lamp illuminates to indicate that the 3-phase power is not correctly wired into the power supply. Change the wiring at the power supply connection to correct the phase order.

5.4 Selector Switch

When the selector switch is moved to the "RUN" position, the PowerDry 4800D Pro E starts dehumidifying. The machine will continue to dehumidify in all conditions until the power is turned off. No dehumidistat is provided to monitor process inlet air condition (see over-dry warning section 3.5). An external control (dehumidistat, thermostat or other contact) can be wired in place of the jumper across terminals 3040 and 3042. The external control must be designed to operate a 115 VAC circuit.

The PowerDry 4800D Pro E has one control device, the power switch. When the power switch is moved to the "on" position your portable desiccant is dehumidifying. The machine will continue to dehumidify in all conditions until the power is turned off: There is no dehumidistat (see over-dry warning section 2.2).

5.5 Alarm (Light and Horn)

The alarm indicator lamp illuminates (and horn sounds) to indicate that a fault condition exists. The fault conditions could be:

- Motor Overload (process or reactivation)
- Reactivation Temperature greater than 375°F
- No dehumidification (i.e. saturated wheel)
- Low reactivation airflow
- Stuck heater contactor

An external alarm can be wired to terminals 3080 (power) and X2 (neutral). This would supply 115 VAC during an alarm condition.

5.6 Hour Meter

The hour meter will run whenever the PowerDry 4800D Pro E is operating. This hour meter measures the cumulative time of operation in one-tenth hour increments. This meter is often used to verify hours on a job or to schedule maintenance.

6 Maintenance

6.1 General Maintenance

A definitive time schedule should be established for inspecting all rotating parts and components. Inspection requirements depend on the frequency of operation, transport, and operating conditions. Periodically check the condition of the air filter, rotating parts, and fasteners to ensure they are secure and in proper working order. Periodically check airflow to make sure there are no obstructions to airflow in outlet or inlet ductwork.

Recommended minimum inspections:

- Upon installation
- After 1 week of operation.
- Annually thereafter or upon loss of performance.



6.2 Cabinet

CAUTION

Disconnect power before removing access panels.

Remove panel fasteners and panels from unit to access internal components. The condition of the cabinet gaskets should be observed during inspection and servicing to insure a good seal. Any leaks must be sealed and panels securely fastened for proper dehumidifier operation.

6.3 Filter

The maintenance interval for the filter depends directly on the cleanliness of the air entering the dehumidifier. It is suggested that a program be established to assure that the filters are replaced or cleaned prior to becoming clogged to the point they create a system problem.

Three aluminum (20"x20"x2") air filters must be checked regularly. Two filters are located near the process air inlet. The other one is located near the reactivation air inlet.

Wash the filters with fresh water. Clean the filter from the downstream side, forcing debris toward the filter inlet. Dry the filters completely before installing them in unit. Replacement filters can be ordered from the factory or purchased locally if available.

DO NOT operate the unit without the filters or with less effective filters as the desiccant wheel inside the unit will become clogged and require disassembly to clean.

6.4 Blower and Motor

Blower and motor bearings are permanently lubricated and do not require maintenance. Blower wheel - inspect wheel blades for accumulation of dust and dirt. Clean thoroughly with compressed air and or vacuum. The wheel should not strike the housing or the inlet ring. Make sure wheel is rotating in the proper direction.

6.5 Drive Motor

The media drive motor is permanently lubricated and requires no maintenance.

6.6 Rotor Drive Chain

A spring loaded tensioner keeps the chain sufficiently tensioned. Check the chain for signs of excessive wear. Replace as necessary. If additional tension is required, simply tighten the nuts on the tension springs as required.

6.7 Seals

High temperature seals separate the process and reactivation compartments. Normally, the seals will not require service or replacement. However, should damage occur, or if poor performance as the result of an air leak is suspected, the following inspection must be performed to determine whether the seals should be replaced:

Inspection:

- 1) Turn the unit off and remove the access covers.
- 2) Visually inspect for gaps between the desiccant media and the seals.
- 3) If significant gaps, wear, or damage are observed, the seal needs to be replaced.



6.8 Desiccant Media

The silica gel desiccant media supplied with the dehumidifier will last indefinitely under ideal conditions. Due to the nature of desiccants they make very good filters. The life of the desiccant is directly related to the airborne contaminants passed through it. Atmospheric contaminants, exposure to acidic gases/or air streams, and contact with petroleum based airborne particles can reduce the efficiency of the desiccant media. The preferred method of cleaning is to blow dust out with compressed air. Proper filtration and preventing contact with chemicals will greatly improve the life of the desiccant. Inspect the face of the media to see that no surface damage has occurred. If damage is noticed, please contact Therma-Stor at 1-800-533-7533 for assistance. The rotor should turn smoothly upon the shaft, if not check the support bearings.

CAUTION

Servicing the Quest PowerDry 4800D Pro E with its high voltage circuitry presents a health hazard which could result in death, serious bodily injury, and/or property damage. Only qualified service people should service this unit.

CAUTION

***ELECTRICAL SHOCK HAZARD:** Electrical power must be present to perform some tests; these tests should be performed only by a qualified service person.*



7 Panel Layout/Wiring Diagram

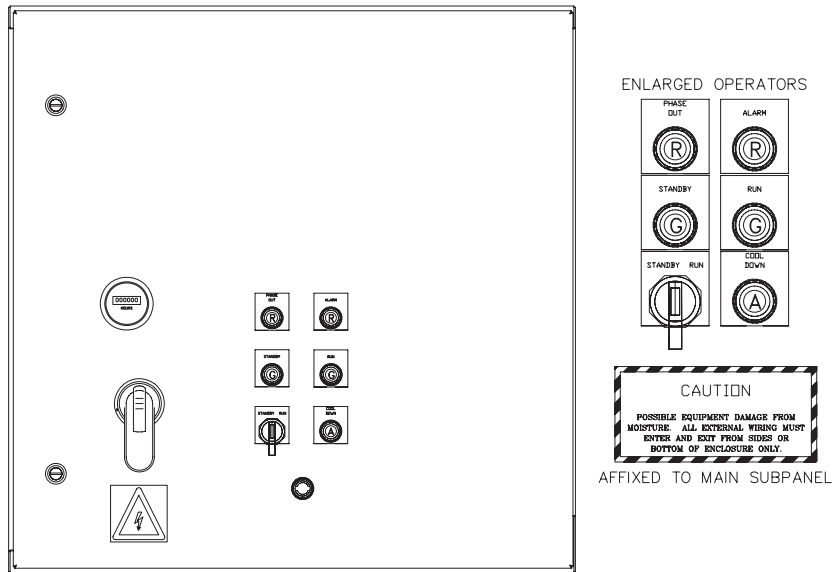

SUB-PANEL

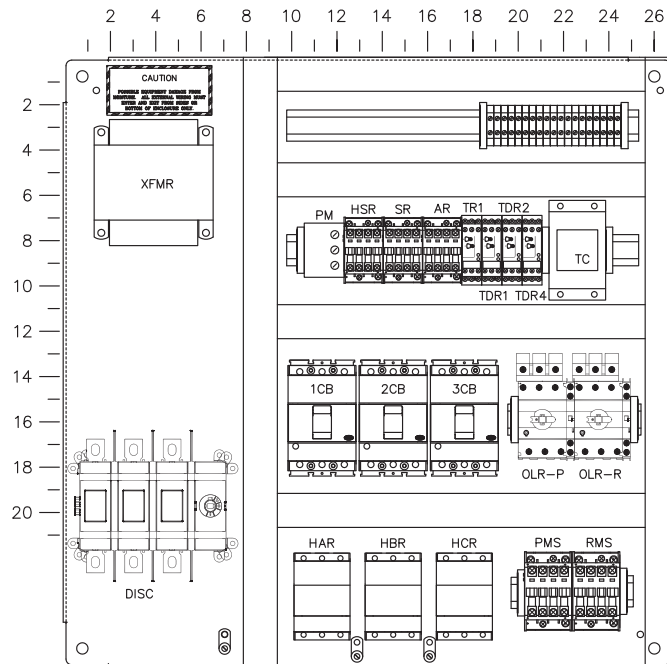

ENLARGED TERMINALS

1
X2
X2
X2
3010
3040
3042
3044
3044
3060
3060
3150
3224
3226
3370
3400
3420
3470

GND
GND



Quest PowerDry 4800D Pro E Installation, Operation and Maintenance Instructions

POWER DISTRIBUTION

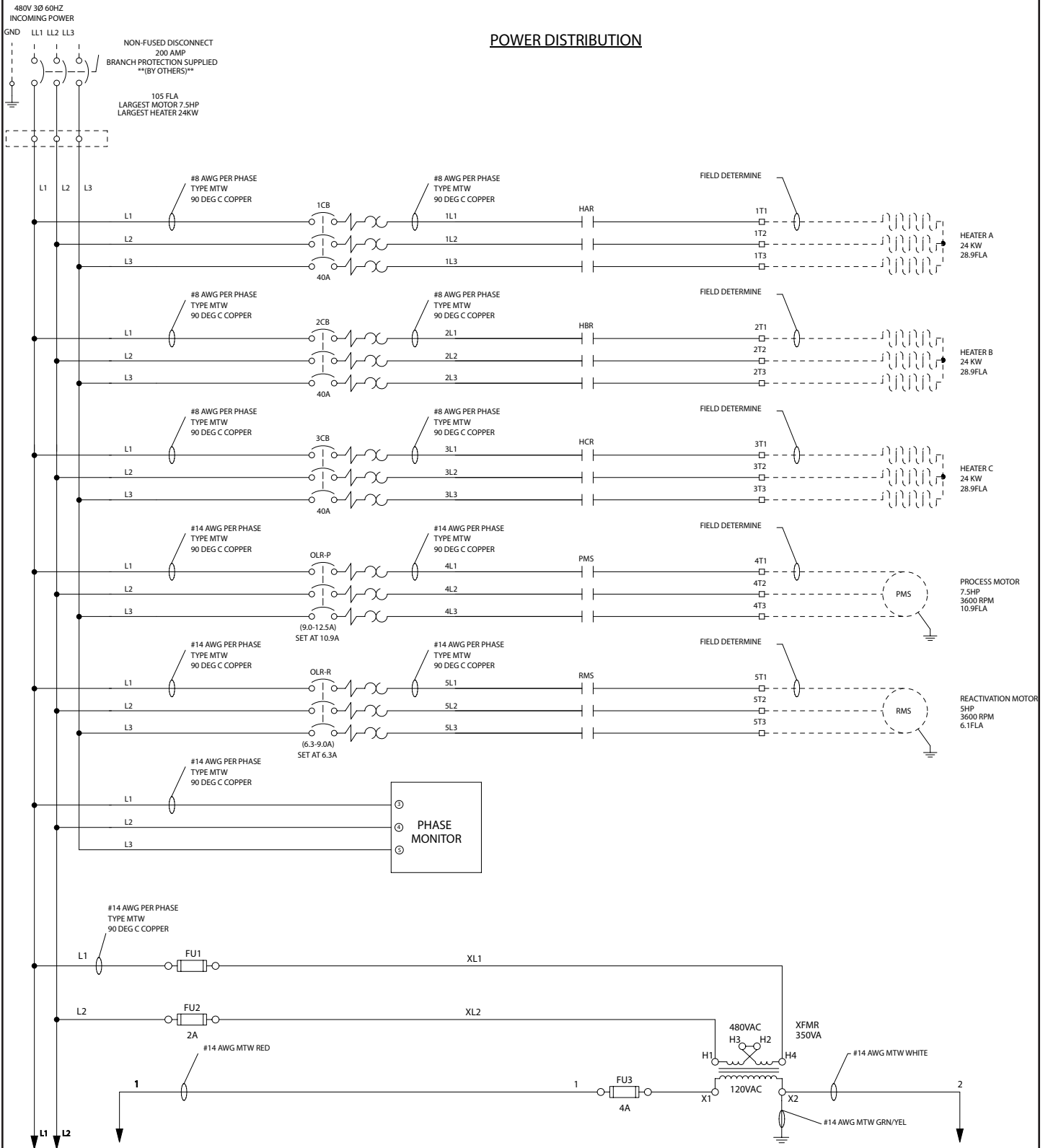

Quest PowerDry 4800D Pro E Installation, Operation and Maintenance Instructions

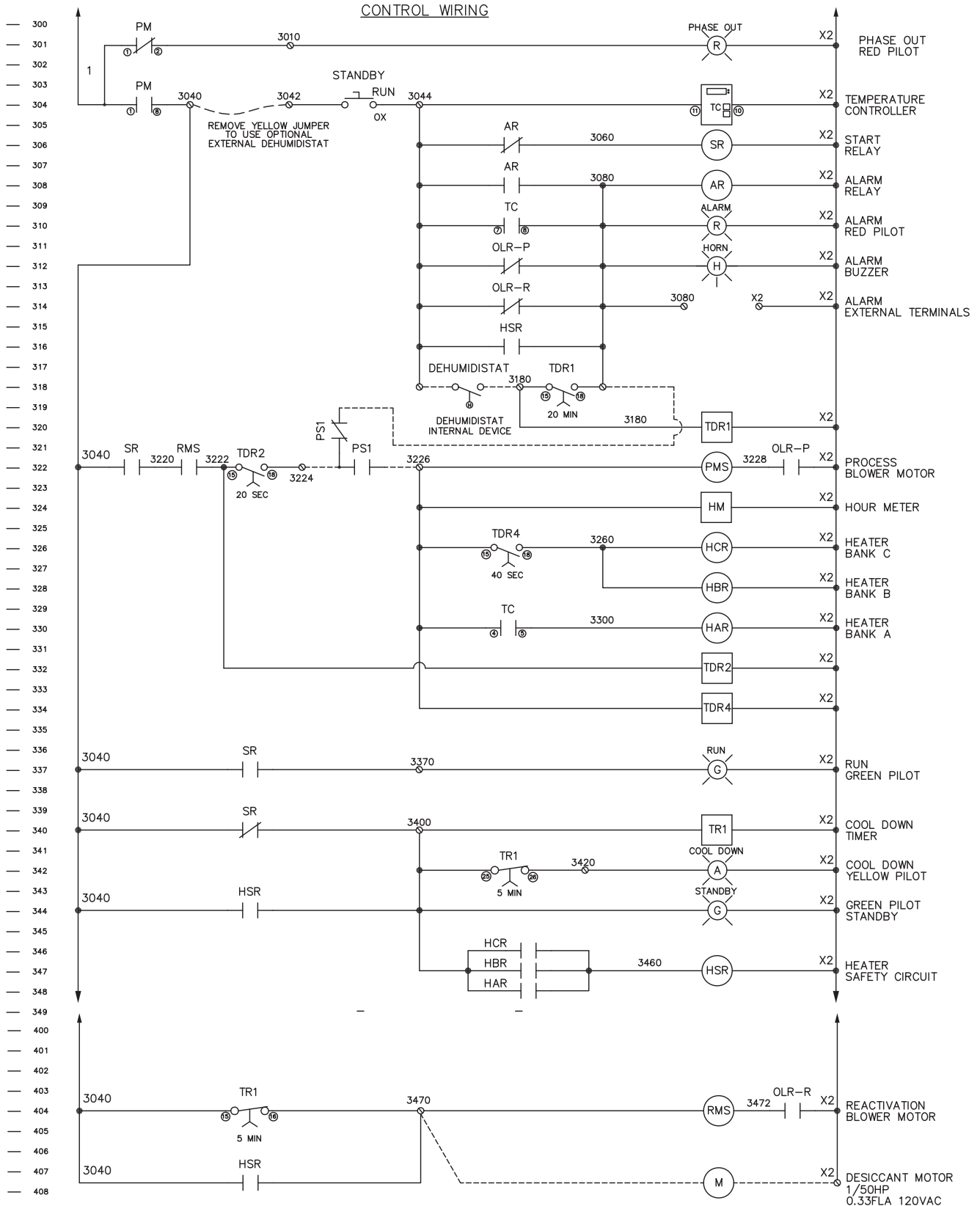

8 Troubleshooting

Trouble	Probable Fault	Probable Cause	Corrective Action
Unit Stopped (fan off, no heater)	Power/Control Failure	<ol style="list-style-type: none"> 1. Main power off 2. Main disconnect open 3. Selector switch open 4. Dehumidistat 	Check main power and cable Close or replace disconnect Close or replace switch Repair or replace
Fan off (Rotor turns)	Power/Mechanical Failure	<ol style="list-style-type: none"> 1. Motor circuit breaker or overload tripped 2. Contactor failure 3. Motor winding failure 4. Fan motor failure 	Reset circuit breaker or overload Repair or replace Repair or replace Repair or replace
Unit running but humidity rises	Excessive infiltration of humid air into the controlled area	<ol style="list-style-type: none"> 1. Excessive unconditioned make-up air 2. Leaking ducts or air handling equipment outside controlled area 3. Access opening to area not sealed 4. Area not vapor tight 	Reduce make-up air Seal leaks Close and seal Seal with paint or vapor barrier
	Faulty humidity controls	<ol style="list-style-type: none"> 1. Dehumidistat needs adjustment 2. Improper settings 3. Defective 	Re-adjust Re-adjust Replace
	Inadequate air flow	<ol style="list-style-type: none"> 1. Dirty filter 2. Obstruction at inlet, outlet or ducting 3. Clogged desiccant media (high pressure differential across media) 	Clean or replace Remove obstruction Remove and replace media rotor
	Inadequate or no reactivation heat	<ol style="list-style-type: none"> 1. Element failure 2. Low / no voltage 3. Control elements failure 	Check elements – repair or replace Correct power supply / breakers Control set point / repair or replace
	Air seals and gaskets	<ol style="list-style-type: none"> 1. Air leaking into dehumidifier 2. Air bypassing media or leaking seals 	Replace access door gaskets Check media position, replace seals
	Ineffective desiccant media	<ol style="list-style-type: none"> 1. Chain 2. Motor/gear box 3. Damaged desiccant rotor 4. Contaminated or damaged desiccant 	Repair or replace Repair or replace Repair or replace Replace desiccant rotor



10 Detailed Sequence of Events – Control Operation

1. Turning on Main Disconnect at dehumidifier provides 480 VAC, 3 phase power to the control panel. Power is distributed to breakers for blower motors, heaters and the control transformer. The control transformer supplies 115 VAC for control system and desiccant wheel motor. PHASE OUT lamp, if illuminated, indicates the power supply is not connected correctly. Rewire power supply as needed.
 - a. STANDBY lamp illuminates.
 - b. Rotor motor terminals, 3470 and X2, energize providing the desiccant motor with 115 VAC power. Desiccant wheel begins to rotate.
 - c. Reactivation motor starter RMS contacts close, starting the reactivation blower.
 - d. COOL DOWN light illuminates, indicating the timed heater cool down cycle has started.
 - e. Time relay TR1 starts the 5 minute heater cool down cycle. Contacts are normally closed, timed open (NCTO). Following the delay...
 - I. TR1 relay energizes, opening contacts for the COOL DOWN light and reactivation blower motor starter (RMS). Rotor motor terminals 3470 and X2 de-energize.

Note: The cool down cycle can be interrupted if the RUN position is selected and no alarm conditions are present.

2. Selecting the RUN position (selector switch) ...
 - a. Provides power to the temperature control TC.
 - b. Start relay SR energizes, if no alarm conditions are present (AR relay de-energized)
 - I. Time relay TR1 and COOL DOWN light de-energize. Run indicator illuminates. Reactivation blower motor starter is energized. Pressure switch PS1 is activated when reactivation airflow reaches minimum level.
 - II. TDR2 starts a 20 second delay followed by energizing Process motor start (PMS), hour meter, and TDR4 40sec timer. If pressure switch PS1 was not activated in previous step due to lack of airflow, Alarm relay is energized and unit is not allowed to run.
 - III. Heater "A" Relay HAR energizes, if auxiliary contacts of the reactivation motor overload (RMS) are closed and the temperature control is calling for heat.
 - IV. Upon TDR4 reaching 40seconds, remaining heat contactors HBR and HCR are energized
3. If temperature in reactivation heater plenum exceeds 375°F, the temperature control TC will close its auxiliary contact, energizing the latching alarm relay AR.
 - a. ALARM lamp illuminates.
 - b. Alarm horn sounds.
 - c. Terminals 3080 and X2 energize. These terminals can be utilized for an external alarm (1 amp maximum).
 - d. Time relay TR1 starts the 5 minute heater cool down cycle. Following the delay...
 - I. TR1 relay energizes, opening contacts for the COOL DOWN light and reactivation blower motor starter (RMS). Rotor motor terminals 3470 and X2 de-energize.

Reset alarm by turning the selector switch to STANDBY.

Probable causes for a high temperature fault are reduced air flow, dirty filter, incorrect reactivation blower rotation, or blower failure.



4. On a fault from an overload relay (OLR-P or OLR-R), the latching alarm relay (AR) energizes. The effect is listed in lines 3a through 3d.

Turn the selector switch to STANDBY, allowing the cool down cycle to complete before turning OFF the main disconnect. Follow Lock Out – Tag Out procedure to de-energize the power cord supplying the 4800. Reset the overload relay located in the control cabinet. Close and secure cabinet door. Energize unit following proper Lock Out – Tag Out procedure.

Probable causes for a fault from an overload relay are insufficient restriction of airflow (overloading motor by allowing excessive airflow) or blower/motor failure.

5. On a fault from the internal process dehumidistat that persists for 20 minutes, the latching alarm relay (AR) energizes. The effect is listed in lines 3a through 3d. TDR1 provides a 10 minute delay for the removal of residual humidity desiccant during startup.

Reset alarm by turning the selector switch to STANDBY.

Probable causes for a fault from the internal dehumidistat are heater failure or desiccant failure.

6. On a fault from a stuck heater contactor, the Alarm Relay will energize and the reactivation blower will remain on continuously. The Rotor will continue to turn, but the process blower will NOT come on. Shut off power with the main disconnect and replace the inoperable contactor to clear the error.

No dehumidistat is provided to monitor process inlet air condition (see over-dry warning section 3.5). An external control (dehumidistat, thermostat or other dry contact) can be wired in place of the jumper across terminals 1 and 3082. The external control must be designed to operate a 115 VAC circuit. Contact closure will start dehumidification. A control wired across terminals 1 and 3082 will be in series with the selector switch. Turn the selector switch to RUN to operate the dehumidifier from an external control.

9 Service Parts

Item	Part No.	Qty.	Description
1	4027228	1	Blower, Reactivation, 460V, 5HP
2	4027229	1	Blower, Process, 460V, 7.5HP
3	4028630	1	Probe, Thermocouple, Type J, 12"
4	4028633	3	Heating Element, 24KW
5	4020175	1	Dehumidistat
6	4028771	1	Temperature Controller with Control Output Board, Relay SPST
7	4028624	1	Control Box
8	4030198	2	Fuse 2A
9	4030199	1	Fuse 4A



Quest PowerDry 4800D Pro E Desiccant Dehumidifier Limited Warranty

Warrantor:

Therma-Stor LLC
4201 Lien Rd
Madison, WI 53704
Telephone: 1-866-933-7486

Who Is Covered: This warranty extends only to the original end-user of the Quest PowerDry 4800D Pro E desiccant dehumidifier, and may not be assigned or transferred.

One Year Warranty: Therma-Stor LLC warrants that, for one (1) year the Quest PowerDry 4800D Pro E desiccant dehumidifier will operate free from any defects in materials and workmanship, or Therma-Stor LLC will, at its option, repair or replace the defective part(s), free of any charge.

End-User Responsibilities: Warranty service must be performed by a Servicer authorized by Therma-Stor LLC. If the end-user is unable to locate or obtain warranty service from an authorized Servicer, the end-user should call Therma-Stor LLC at the above number and ask for the Therma-Stor Service Department., which will then arrange for covered warranty service. Warranty service will be performed during normal working hours.

The end-user must present proof of purchase (lease) upon reQuest, by use of the warranty card or other reasonable and reliable means. The end-user is responsible for normal care. This warranty does not cover any defect, malfunction, etc. resulting from misuse, abuse, lack of normal care, corrosion, freezing, tampering, modification, unauthorized or improper repair or installation, accident, acts of nature or any other cause beyond Therma-Stor LLC' reasonable control.

Limitations and Exclusions: If any Quest PowerDry 4800D Pro E Desiccant Dehumidifier part is repaired or replaced, the new part shall be warranted for only the remainder of the original warranty period applicable thereto (but all warranty periods will be extended by the period of time, if any, that the Quest PowerDry 4800D Pro E Desiccant Dehumidifier is out of service while awaiting covered warranty service).

UPON THE EXPIRATION OF THE WRITTEN WARRANTY APPLICABLE TO THE Quest PowerDry 4800D Pro E DESICCANT DEHUMIDIFIER OR ANY PART THEREOF, ALL OTHER WARRANTIES IMPLIED BY LAW, INCLUDING MERCHANTABILITY AND FITNESS FOR A PARTICULAR PURPOSE, SHALL ALSO EXPIRE. ALL WARRANTIES MADE BY THERMA-STOR LLC ARE SET FORTH HEREIN, AND NO CLAIM MAY BE MADE AGAINST THERMA-STOR LLC BASED ON ANY ORAL WARRANTY. IN NO EVENT SHALL THERMA-STOR LLC, IN CONNECTION WITH THE SALE, INSTALLATION, USE, REPAIR OR REPLACEMENT OF ANY Quest PowerDry 4800D Pro E DESICCANT DEHUMIDIFIER OR PART THEREOF BE LIABLE UNDER ANY LEGAL THEORY FOR ANY SPECIAL, INDIRECT OR CONSEQUENTIAL DAMAGES INCLUDING WITHOUT LIMITATION WATER DAMAGE (THE END-USER SHOULD TAKE PRECAUTIONS AGAINST SAME), LOST PROFITS, DELAY, OR LOSS OF USE OR DAMAGE TO ANY REAL OR PERSONAL PROPERTY.

Some states do not allow limitations on how long an implied warranty lasts, and some do not allow the exclusion or limitation of incidental or consequential damages, so one or both of these limitation may not apply to you.

Legal Rights: This warranty gives you specific legal rights, and you may also have other rights which vary from state to state.

